

DWG #	DRAWING DESCRIPTION	REV DATE	REV #
1.0	ELECTRICAL SERVICE STANDARDS TABLE OF CONTENTS	2/7/2025	0.0
2.2	ELECTRICAL SERVICE INFORMATION - RESIDENTIAL POWER SERVICE	1/11/2025	0.0
2.3	ELECTRICAL SERVICE INFORMATION - MULTI-FAMILY & COMMERCIAL POWER SERVICE	1/11/2025	0.0
2.4	SERVICE UPGRADE PROCESS & REQUIREMENTS RESIDENTIAL & COMMERCIAL POWER SERVICE	1/11/2025	0.0
3.2.1	UNDERGROUND SERVICE 100-400 AMP (1 PHASE) CONSTRUCTION POWER SERVICE	1/13/2025	0.0
3.2.2	UNDERGROUND SERVICE 100-400 AMP (1 PHASE) RESIDENTIAL POWER SERVICE	1/13/2025	0.0
3.2.3	FREE STANDING METER 100-400 AMP (1 OR 3 PHASE) TYPICAL INSTALLATION	1/13/2025	0.0
3.2.4	PEDESTAL METER 100-200 AMP (1 PHASE) TYPICAL INSTALLATION	1/13/2025	0.0
3.2.5	OVERHEAD SERVICE 100-200 AMP (1 PHASE) RESIDENTIAL & COMMERCIAL POWER SERVICE	1/13/2025	0.0
3.3.1	RISER POLE (OVERHEAD TO UNDERGROUND) (LOCATIONS IN THE P.U.E.)	2/6/2025	0.0
3.3.2	COMMUNICATION SPACE & ATTACHMENT (OVERHEAD)	2/6/2025	0.0
4.1.0	CONNECTION DETAIL TO EXISTING ENERGIZED EQUIPMENT RESIDENTIAL & COMMERCIAL POWER SERVICE	1/13/2025	0.0
4.1.1	TRANSFORMER SINGLE PHASE (LOCATIONS IN THE P.U.E.)	1/13/2025	0.0
4.1.2	SECONDARY JUNCTION BOX (SECONDARY PEDESTAL) (LOCATIONS IN THE P.U.E.)	2/4/2025	0.0
4.1.3	GROUND SLEEVE/SECTIONALIZER (TYPICAL LOCATION IN THE P.U.E.)	2/6/2025	0.0
4.1.4	PME SWITCHGEAR (LOCATIONS IN THE P.U.E.)	2/6/2025	0.0
4.1.5	TRANSFORMER, JUNCTION BOX & P.U.E LOCATION (DEVELOPMENT WITH COMBO CURB/WALK)	2/7/2025	0.0
4.1.6	TRANSFORMER, JUNCTION BOX & P.U.E LOCATION (DEVELOPMENT WITH CURB PLANTER STRIP & WALK)	2/7/2025	0.0
4.1.7	EQUIPMENT & SPECIAL P..U.E. LOCATION (15' PUE) (DEVELOPMENT WITH CURB & 15' PUE)	2/7/2025	0.0
4.1.8	TRANSFORMER, JUNCTION BOX & P.U.E LOCATION (DEVELOPMENT WITH SWALE, NO CURB)	2/7/2025	0.0
4.1.9	TRANSFORMER PAD 3 PHASE UNDERGROUND SERVICE	2/7/2025	0.0
4.1.10	MANUAL 3-PHASE TRANSFORMER PAD	2/7/2025	0.0
4.2.1	ELECTRICAL TRENCH & CONDUIT NOTES RESIDENTIAL & COMMERCIAL POWER SERVICE	1/20/2025	0.0
4.2.2	POWER TRENCH & JOINT USE TRENCH DETAIL RESIDENTIAL & COMMERCIAL POWER SERVICE	1/20/2025	0.0
4.2.3	POWER TRENCH & CONDUIT THRUST BLOCK (EXAMPLE) RESIDENTIAL & COMM. POWER SERVICE	11/12/2024	0.0
4.2.4	MANDREL TABLE RESIDENTIAL & COMMERCIAL POWER SERVICE	1/20/2025	0.0
4.2.5	POWER EQUIPMENT EROSION PREVENTION RESIDENTIAL & COMMERCIAL POWER SERVICE	1/20/2025	0.0
5.1	TRANSFORMER & EQUIPMENT REQUIRED CLEARANCES RESIDENTIAL & COMMERCIAL POWER SERVICE	2/7/2025	0.0
5.2	TRANSFORMER & EQUIPMENT REQUIRED CLEARANCES RESIDENTIAL & COMMERCIAL POWER SERVICE	2/7/2025	0.0
5.3	CLEARANCE REQUIRED FOR SECONDARY JUNCTION BOX RESIDENTIAL & COMMERCIAL POWER SERVICE	2/7/2025	0.0
5.4	CLEARANCE TO COMBUSTIBLE STRUCTURES FROM TRANSFORMERS (LOCATED IN THE P.U.E.)	2/7/2025	0.0
5.5	CLEARANCES FOR SERVICE DROPS <600 VOLT FOR BUILDINGS, SIGNS & OTHER INSTALLATIONS RESIDENTIAL & COMMERCIAL POWER SERVICE	2/7/2025	0.0
6.1.1	METER SOCKET SINGLE PHASE WIRING DIAGRAM 120/240 VOLT OR 120/208 VOLT 100-200 AMP RESIDENTIAL OR COMMERCIAL	11/14/2024	0.0
6.1.2	METER SOCKET UP TO 400 AMP WIRING DIAGRAM 3 WIRE WYE 1 PHASE 120/240 VOLT OR 277/480 VOLT (5 TERMINAL SOCKET W/ LINK BY-PASS)	11/14/2024	0.0
6.1.3	MULTI-METER INSTALLATION UNDERGROUND SERVICE 200 AMP & GREATER, SELF CONTAINED METERING	1/20/2025	0.0
6.2.1	ELECTRICAL SERVICE REQUIREMENTS CT METERING 800 AMP MAX. COMMERCIAL/1 PHASE-3 PHASE POWER SERVICE	11/14/2024	0.0
6.3.1	REQUIREMENTS FOR ELECTRIC SERVICE SWITCHBOARD METERING OVER 400 AMP COMMERCIAL & INDUSTRIAL 3 <sup>A</sup> POWER	11/14/2024	0.0
6.3.2	SWITCHBOARD SERVICE 800 AMP & GREATER COMMERCIAL AND INDUSTRIAL SERVICES	11/14/2024	0.0
6.3.3	SWITCHBOARD SERVICE 800 AMP & GREATER COMMERCIAL AND INDUSTRIAL SERVICES	11/14/2024	0.0



**REQUIREMENTS & STANDARDS  
ELECTRICAL SERVICE  
STANDARDS  
TABLE OF CONTENTS**

DWG: **1.0**

REV. 0.00

BY: JB/MA

DATE: 2/7/25

## TEMPORARY CONSTRUCTION POWER:

TEMPORARY POWER WILL BE ON A CASE-BY-CASE BASIS AT HEBER LIGHT & POWER'S DISCRETION AND SHALL NOT LAST MORE THAN ONE YEAR.

## PERMANENT POWER:

ALL PERMANENT ELECTRICAL SERVICE INSTALLATIONS SHALL MEET HEBER LIGHT & POWER SERVICE SPECIFICATIONS, NATIONAL ELECTRICAL CODE AND NATIONAL ELECTRICAL SAFETY CODE LATEST REVISIONS, NO CUSTOMER OWNED EQUIPMENT BETWEEN METER BASE AND METER. ADDRESS SHALL BE POSTED AT BUILDING SITE.

HEBER LIGHT & POWER SERVICE SPECIFICATIONS ARE PUBLISHED ON THE HEBER LIGHT & POWER WEBSITE UNDER DOCUMENT & POLICY LIBRARY-GENERAL INFORMATION ([https://www.heberpower.com/company-information/documents-policy-library/.](https://www.heberpower.com/company-information/documents-policy-library/))

MAXIMUM RESIDENTIAL SERVICE IS SINGLE PHASE 800 AMPS.

IMPACT FEE APPLICATION MUST BE COMPLETED BY OWNER BUILDER/CONTRACTOR PRIOR TO CONNECTION OF PERMANENT ELECTRICAL SERVICE. INSPECTION FROM AUTHORITY HAVING JURISDICTION (THE LOCAL/MUNICIPAL INSPECTING AUTHORITY) MUST BE COMPLETED PRIOR TO CONNECTION OF PERMANENT ELECTRICAL SERVICE.

HEBER LIGHT & POWER SHALL INSPECT TRENCH AND CONDUIT INSTALLATION PRIOR TO BACKFILL. (CALL WITH 48 HOURS NOTICE TO SCHEDULE ELECTRICAL SERVICE TRENCH INSPECTIONS.) ANY BOXES SET BY DEVELOPER SHALL BE INSPECTED PRIOR TO BACKFILL.

ALL NEW DEVELOPMENTS WILL BE SERVICED UNDERGROUND; OWNER/DEVELOPER WILL BE RESPONSIBLE TO PROVIDE AND INSTALL ALL UNDERGROUND CONDUIT. TRANSFORMER PADS, SECONDARY JUNCTION BOXES, GROUND SLEEVE BASES AND SWITCH BASES WILL BE PROVIDED BY HEBER LIGHT & POWER AND INSTALLED BY CONTRACTOR. THE UNDERGROUND ELECTRICAL DISTRIBUTION LAYOUT SHALL BE COMPLETED BY OR APPROVED BY HEBER LIGHT & POWER.

ALL SERVICES REQUIRE SCH. 40 PVC CONDUIT AND RIGID METAL CONDUIT (RMC) LONG SWEEP (LS) 90 BEND AND RISER WITH LUG CONNECTION TO MAIN/METER BASE. FOR SINGLE FAMILY RESIDENTIAL SERVICE HEBER LIGHT & POWER WILL PROVIDE THE CONDUCTOR FROM THE SOURCE TO THE MAIN/METER BASE UP TO 200 FEET MAXIMUM (SEE 3.2.1-3.2.4, & 6.1.4. FOR LONGER LENGTHS CONSULT WITH HEBER LIGHT & POWER FOR ADDITIONAL COST).

FOR SINGLE FAMILY RESIDENTIAL SERVICE HEBER LIGHT & POWER WILL DO THE INITIAL WIRE PULL. AFTER INITIAL INSTALLATION THE CUSTOMER WILL BE RESPONSIBLE FOR ALL COSTS TO MAINTAIN/REPLACE CONDUIT AND CONDUCTOR FROM THEIR RESIDENCE UP TO THE SECONDARY BOX, TRANSFORMER OR POWER SERVICE MAST (I.E., THE POWER SOURCE.) TEMPORARY FIXES BY HEBER LIGHT & POWER WILL ONLY BE FOR 30 DAYS MAXIMUM.

THE DEVELOPER/CONTRACTOR SHALL BE CHARGED FOR ALL BROKEN/DAMAGED EQUIPMENT UP TO THE TIME THE HOMEOWNER TAKES OCCUPANCY.

GENERAL RULES FOR THE SERVICE LOCATION ARE AS FOLLOWS: THE METER AND MAIN DISCONNECT SHALL BE SETBACK FROM THE FRONT CORNER OF THE STRUCTURE A MAXIMUM OF 15 FEET. METER SHALL BE A MINIMUM OF 3 FEET AWAY FROM GAS SERVICE AND 3 FEET AWAY FROM WINDOWS THAT OPEN AND FROM DOORS.

THE METER & MAIN DISCONNECT SHALL BE ON THE SIDE OF THE STRUCTURE CLOSEST TO THE DISTRIBUTION POWER SOURCE INTENDED FOR THAT SITE. IF A STUB-OUT IS AVAILABLE IT SHALL BE USED. METER SHALL NOT BE LOCATED MORE THAN 200 FEET FROM THE DISTRIBUTION POWER SOURCE. IF IT IS MORE THAN 200 FEET, ADDITIONAL LINE EXTENSION COSTS WILL BE AT CUSTOMER'S EXPENSE.



## REQUIREMENTS & STANDARDS ELECTRICAL SERVICE INFORMATION

RESIDENTIAL POWER SERVICE

DWG: **2.2**

REV. 0.00

BY: JB/MA

DATE: 1/11/25

## TEMPORARY CONSTRUCTION POWER:

ALL TEMPORARY ELECTRICAL SERVICE INSTALLATIONS SHALL MEET HEBER LIGHT & POWER SPECIFICATIONS, NATIONAL ELECTRICAL CODE, AND NATIONAL ELECTRICAL SAFETY CODE LATEST REVISIONS. ADDRESS SHALL BE POSTED AT BUILDING SITE.

TEMPORARY POWER WILL BE ON A CASE-BY-CASE BASIS AT HEBER LIGHT & POWER'S DISCRETION. HEBER LIGHT & POWER REQUIRES OWNER/BUILDER TO SUPPLY AND INSTALL THE PERMANENT SERVICE INCLUDING METER BASE, DISCONNECTS AND OUTLETS. (SEE DETAIL 3.2.1) OWNER/BUILDER SHALL HAVE A BUILDING PERMIT NUMBER PRIOR TO MAKING APPLICATION FOR TEMPORARY POWER.

OWNER SHALL GO TO <https://www.heberpower.com/impact-fee-application/> TO MAKE APPLICATION FOR SERVICE OR CONTACT HEBER POWER & LIGHT AT (435) 654-1581.

TEMPORARY POWER CONNECTS FOR COMMERCIAL CONSTRUCTION MAY USE THE PERMANENT TRANSFORMER FOR THE PROJECT, OR RENT A TEMPORARY TRANSFORMER FROM HEBER LIGHT & POWER. SEE THE FEE SCHEDULE FOR CHARGES ASSOCIATED WITH TEMPORARY POWER. ADDITIONAL FEES MAY BE NECESSARY DEPENDING ON SIZE AND TYPE OF TEMPORARY POWER REQUEST.

## PERMANENT POWER:

ALL PERMANENT ELECTRICAL SERVICE INSTALLATIONS SHALL MEET HEBER LIGHT & POWER SERVICE SPECIFICATIONS, NATIONAL ELECTRICAL CODE AND NATIONAL ELECTRICAL SAFETY CODE LATEST REVISIONS, NO CUSTOMER OWNED EQUIPMENT BETWEEN METER BASE AND METER. ADDRESS SHALL BE POSTED AT BUILDING SITE.

HEBER LIGHT & POWER SERVICE SPECIFICATIONS ARE PUBLISHED ON THE HEBER LIGHT & POWER WEBSITE UNDER DOCUMENT & POLICY LIBRARY-GENERAL INFORMATION (<https://www.heberpower.com/company-information/documents-policy-library/>)

APPLICATION FOR PERMANENT ELECTRICAL SERVICE MUST BE COMPLETED BY OWNER BUILDER\CONTRACTOR PRIOR TO CONNECTION OF PERMANENT ELECTRICAL SERVICE. INSPECTION FROM AUTHORITY HAVING JURISDICTION (THE LOCAL/MUNICIPAL INSPECTING AUTHORITY) MUST BE COMPLETED PRIOR TO CONNECTION OF PERMANENT ELECTRICAL SERVICE.

ANY STRUCTURE WITH MORE THAN ONE UNIT SHALL BANK METERS IN A CENTRAL LOCATION. SEE 6.1.4

HEBER LIGHT & POWER SHALL INSPECT TRENCH AND CONDUIT INSTALLATION PRIOR TO BACKFILL. (CALL WITH 48 HOURS NOTICE TO SCHEDULE ELECTRICAL SERVICE TRENCH INSPECTIONS)

GENERAL RULES FOR THE SERVICE LOCATION ARE AS FOLLOWS: THE METER AND MAIN DISCONNECT SHALL BE SETBACK FROM THE FRONT CORNER OF THE STRUCTURE A MAXIMUM OF 15 FEET. METER SHALL BE A MINIMUM OF 3 FEET AWAY FROM GAS SERVICE AND 3 FEET AWAY FROM WINDOWS THAT OPEN AND FROM DOORS.

THE METER & MAIN DISCONNECT SHALL BE ON THE SIDE OF THE STRUCTURE CLOSEST TO THE DISTRIBUTION POWER SOURCE INTENDED FOR THAT SITE. IF A STUB-OUT IS AVAILABLE IT SHALL BE USED. METER SHALL NOT BE LOCATED MORE THAN 200 FEET FROM THE DISTRIBUTION POWER SOURCE. IF IT IS MORE THAN 200 FEET, ADDITIONAL LINE EXTENSION COSTS WILL BE AT CUSTOMER'S EXPENSE.

ALL NEW DEVELOPMENTS WILL BE SERVICED UNDERGROUND; OWNER/DEVELOPER WILL BE RESPONSIBLE TO PROVIDE AND INSTALL ALL UNDERGROUND CONDUIT. TRANSFORMER PADS, SECONDARY JUNCTION BOXES, GROUND SLEEVE BASES AND SWITCH BASES WILL BE PROVIDED BY HEBER LIGHT & POWER AND INSTALLED BY CONTRACTOR. THE UNDERGROUND ELECTRICAL DISTRIBUTION LAYOUT SHALL BE COMPLETED BY OR APPROVED BY HEBER LIGHT & POWER.

ALL SERVICES REQUIRE SCH. 40 PVC CONDUIT AND RMC LONG SWEEP (LS) 90 BEND AND RISER WITH LUG CONNECTION TO MAIN/METER BASE, SUPPLIED AND INSTALLED BY THE OWNER/CONTRACTOR. FOR MULTI FAMILY UNITS AND COMMERCIAL INSTALLATIONS, THE SECONDARY CONDUCTOR SHALL BE SUPPLIED, INSTALLED (PULLED), TERMINATED & MAINTAINED BY OWNER / CONTRACTOR PER NEC, FROM THE METER BASE TO THE POWER SOURCE SUPPLIED BY HEBER LIGHT & POWER. AFTER INITIAL INSTALLATION THE CUSTOMER WILL BE RESPONSIBLE FOR ALL COSTS TO MAINTAIN/REPLACE CONDUIT AND CONDUCTOR FROM POWER SOURCE.

DEVELOPER/CONTRACTOR SHALL BE CHARGED FOR ALL BROKEN/DAMAGED EQUIPMENT UP TO THE TIME THE OWNER TAKES POSSESSION.



## REQUIREMENTS & STANDARDS ELECTRICAL SERVICE INFORMATION

**MULTI-FAMILY & COMMERCIAL POWER SERVICE**

DWG: **2.3**

REV. 0.00

BY: JB/MA

DATE: 1/11/25

# PRE-INSPECTIONS REQUIRED ON ALL SERVICE UPGRADES.

APPLICATION FOR ELECTRICAL SERVICE UPGRADE MUST BE COMPLETED BY OWNER/CONTRACTOR PRIOR TO ELECTRICAL SERVICE UPGRADE. ALL SERVICE UPGRADES REQUIRE A PRE-INSPECTION AND IMPACT FEE PAYMENT.

ALL ELECTRICAL SERVICE UPGRADE INSTALLATIONS SHALL MEET HEBER LIGHT & POWER / BUILDING INSPECTION SERVICE SPECIFICATIONS, NATIONAL ELECTRICAL CODE AND NATIONAL ELECTRICAL SAFETY CODE LATEST REVISIONS.

**ADDRESS SHALL BE POSTED AT BUILDING SITE.**

METER & SERVICE LOCATIONS ARE TO BE DETERMINED BY HEBER LIGHT & POWER. GENERAL RULES FOR THE SERVICE LOCATION ARE AS FOLLOWS: THE METER AND MAIN DISCONNECT SHALL BE SETBACK FROM THE FRONT CORNER OF THE STRUCTURE A MAXIMUM OF 15 FEET. METER SHALL BE A MINIMUM OF 3 FEET AWAY FROM GAS SERVICE AND 3 FEET FROM WINDOWS THAT OPEN AND FROM DOORS. THE METER & MAIN DISCONNECT SHALL BE ON THE SIDE OF THE STRUCTURE CLOSEST TO THE DISTRIBUTION POWER SOURCE INTENDED FOR THAT SITE. IF A STUB-OUT IS AVAILABLE IT SHALL BE USED. METER SHALL NOT BE LOCATED MORE THAN 200 FEET FROM THE DISTRIBUTION POWER SOURCE. IF IT IS MORE THAN 200 FEET, ADDITIONAL LINE EXTENSION COSTS WILL BE AT CUSTOMER'S EXPENSE.

IF UPGRADING SERVICE, IT MUST COMPLY WITH CURRENT STANDARDS. SEE 3.2.2 FOR CURRENT REQUIREMENTS. ALL SERVICE UPGRADES NOT CONFORMING TO CURRENT HEBER LIGHT & POWER / BUILDING INSPECTION STANDARDS SHALL BE DENIED. LINE SIDE JUNCTION BOXES AND ELECTRICAL GUTTERS ARE NOT ALLOWED. ALL UNUSED ELECTRICAL EQUIPMENT SHALL BE REMOVED.

HEBER LIGHT & POWER SHALL INSPECT TRENCH AND CONDUIT INSTALLATION PRIOR TO BACKFILL. (CALL WITH 48 HOURS NOTICE TO SCHEDULE ELECTRICAL SERVICE TRENCH INSPECTIONS)

NOTE: FOR MULTI-METER INSTALLATIONS ALL METER BASES SHALL BE LABELED AS WELL AS EACH INSIDE BREAKER PANEL WITH A PERMANENT LABEL.

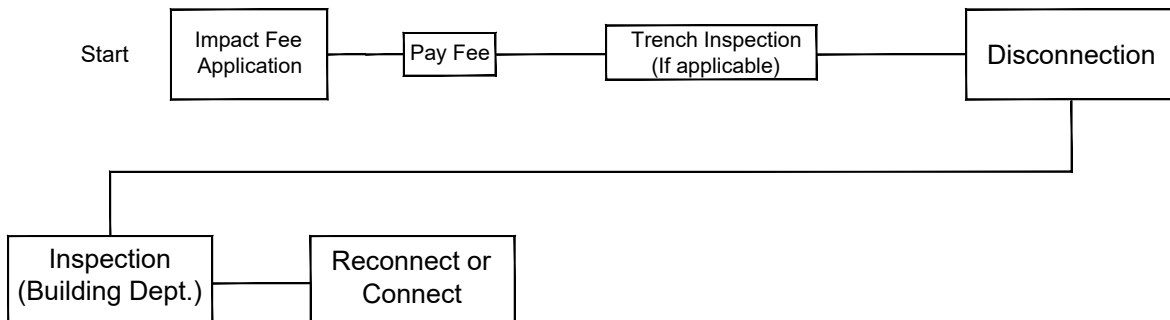

## REQUIREMENTS & STANDARDS

# SERVICE UPGRADE PROCESS & REQUIREMENTS

RESIDENTIAL & COMMERCIAL POWER SERVICE

DWG: **2.4**

REV. 0.00

BY: JB/MA

DATE: 1/11/25



**NOTE FOR CABIN COMMUNITIES WITH UNDERGROUND SERVICES:  
INSTALL A FREE-STANDING METER (DWG. 3.2.3) WITHIN 20 FEET OF TRANSFORMER OR SECONDARY BOX.**

**TEMP POWER WILL BE ON CASE BY CASE BASIS AT HEBER LIGHT & POWER'S DISCRETION AND SHALL NOT LAST MORE THAN ONE YEAR**

IF HEBER LIGHT & POWER PASSES A TRENCH INSPECTION BUT IT DOES NOT MEET THE REQUIREMENTS AS STATED IN THIS DOCUMENT, HEBER LIGHT & POWER RESERVES THE RIGHT TO HAVE CUSTOMER COMPLY WITH THESE STANDARDS.

THE CUSTOMER SHALL HAVE LOT LINES, PUE'S, AND EASEMENTS SURVEYED PRIOR TO INSTALLING CONDUIT TO VERIFY IT IS IN THE CORRECT LOCATION. ANY RELOCATION/ REINSTALLATION EXPENSES WILL BE THE CUSTOMER'S.

SECONDARY JUNCTION BOX OR TRANSFORMER

BUSHINGS ON CONDUIT ENDS

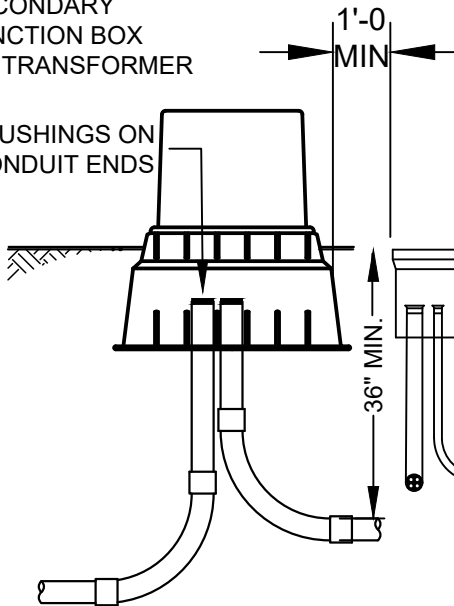

5'-6" TO 6'-0" FROM FINAL GRADE

MAIN SERVICE DISCONNECT REQUIRED OUTSIDE AT THE METER LOCATION.

METER LOCATION SHALL BE APPROVED BY HEBER LIGHT & POWER

**CONNECT RISER CONDUIT TO METER BASE WITH HUB & GROUNDING BUSHING**

ANCHOR RISER CONDUIT TO CONCRETE FOUNDATION WALL. ANCHORS SHALL BE 3" PIPE CLAMP TO 6" MIN. UNI-STRUT WITH (2)  $\frac{5}{16}$ " DIA. ANCHORS WITH 2-1/2" EMBEDMENT (MIN.) 1 ANCHOR SHALL REMAIN ABOVE FINISHED GRADE, AND 1 ANCHOR SHALL BE 2' BELOW THE OTHER.

PONY WALL FOR CONSTRUCTION POWER

BLOCK AS REQ'D FOR VENEER

ADDRESS SHALL BE POSTED AT BUILDING

BUILDING FRAMING WITH BLOCKING FOR ATTACHMENT

GROUND PER NEC

3" DIA. RMC CONDUIT

RIGID COUPLING

RIGID/RMC LONG-SWEEP ELBOW

COMMUNICATIONS BOX (TYP)

COMMUNICATION SERVICE CONDUIT STUBS

SERVICE CONDUIT

2'

**NOTES:**

1. PVC CONDUIT SHALL NOT BE HEATED TO MAKE BENDS. ONLY CONDUIT WITH FACTORY BENDS WILL BE ACCEPTED.
2. SERVICE CONDUIT MUST BE CONTINUOUS FROM SOURCE TO METER BASE.
3. SERVICE CONDUIT DAMAGE IS AT CUSTOMER'S EXPENSE. (HEBER LIGHT & POWER WILL DISCONNECT METER)
4. METAL CONDUIT INSTALLED BELOW GRADE SHALL BE PROTECTED FROM CORROSION BY AN APPROVED COVERING OF PVC TAPE.
5. CONTRACTOR SHALL COMPACT TRENCH AND BACKFILL TO 95% MAX DENSITY



**REQUIREMENTS & STANDARDS  
UNDERGROUND SERVICE  
100-400 AMP (1 PHASE)  
CONSTRUCTION POWER SERVICE**

DWG: **3.2.1**

REV. 0.00

BY: JB/MA

DATE: 1/13/25

ALL NON-CURRENT CARRYING METALLIC PARTS TO BE BONDED TO NEUTRAL AND EFFECTIVELY GROUNDED - PER NEC

ADDRESS SHALL BE POSTED AT BUILDING

**MAIN SERVICE DISCONNECT**  
REQUIRED AT THE METER LOCATION  
CONNECT RISER WITH HUB & GROUNDING BUSHING

METER BASE & MAIN SERVICE DISCONNECT

**SECTION A**

1. CUSTOMER TO FURNISH AND INSTALL CONDUIT FROM TRANSFORMER/SECONDARY JUNCTION BOX, TO METER SOCKET.
2. CONTACT HEBER LIGHT & POWER FOR TRENCH INSPECTION. DO NOT BACKFILL PRIOR TO INSPECTION. REFER TO 4.2.1.
3. SEE TRENCH DETAIL DRAWING FOR SPECIFICATIONS.
4. TRENCH SHALL BE MIN. DEPTH OF 36".
5. HEBER LIGHT & POWER TO SUPPLY CONDUCTOR AFTER INSPECTION HAS BEEN COMPLETED.
6. METER LOCATION MUST BE APPROVED BY HEBER LIGHT & POWER.

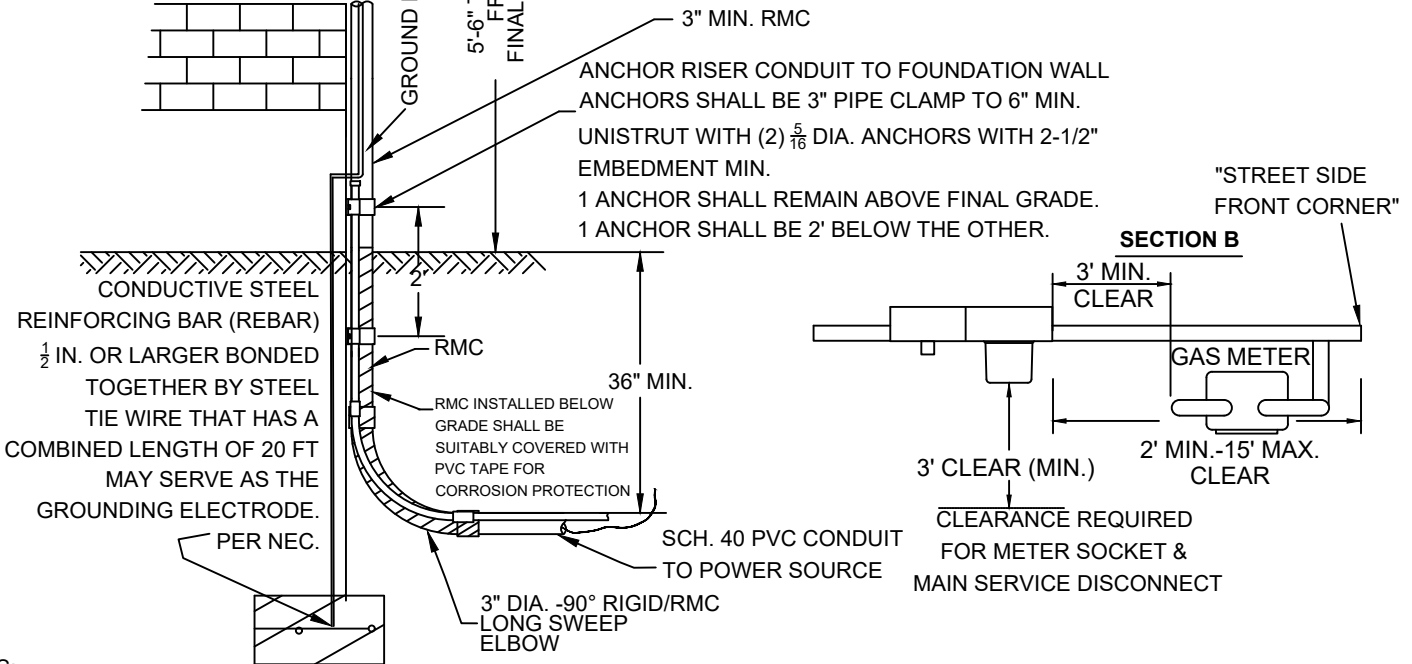

**NOTES:**

1. 100 AMP SERVICE MINIMUM SERVICE SIZE THAT CAN BE INSTALLED (NEC 310.12.)
2. DISTANCE FROM POWER SOURCE TO METER CANNOT EXCEED 200 FEET WITH A MAXIMUM OF TWO 90 DEGREE ELBOWS, WITHOUT ADDITIONAL LINE EXTENSION.
3. PVC CONDUIT SHALL NOT BE HEATED TO MAKE BENDS. ONLY CONDUIT WITH FACTORY BENDS WILL BE ACCEPTED.
4. MULE TAPE SHALL BE PULLED THROUGH CONDUIT BEFORE CONDUCTOR WILL BE PULLED BY HEBER LIGHT & POWER.
5. SERVICE WILL NOT BE CONNECTED UNTIL HEBER LIGHT & POWER HAS INSPECTION REPORT FROM LOCAL MUNICIPALITY.



**REQUIREMENTS & STANDARDS**

**UNDERGROUND SERVICE  
100 - 400 AMP (1 PHASE)**

**RESIDENTIAL POWER SERVICE**

DWG: **3.2.2**

REV. 0.00

BY: JB/MA

DATE: 1/13/25

**NOTE FOR CABIN COMMUNITIES:**  
 INSTALL A FREE-STANDING METER  
 WITHIN 20 FEET OF TRANSFORMER  
 OR SECONDARY BOX.

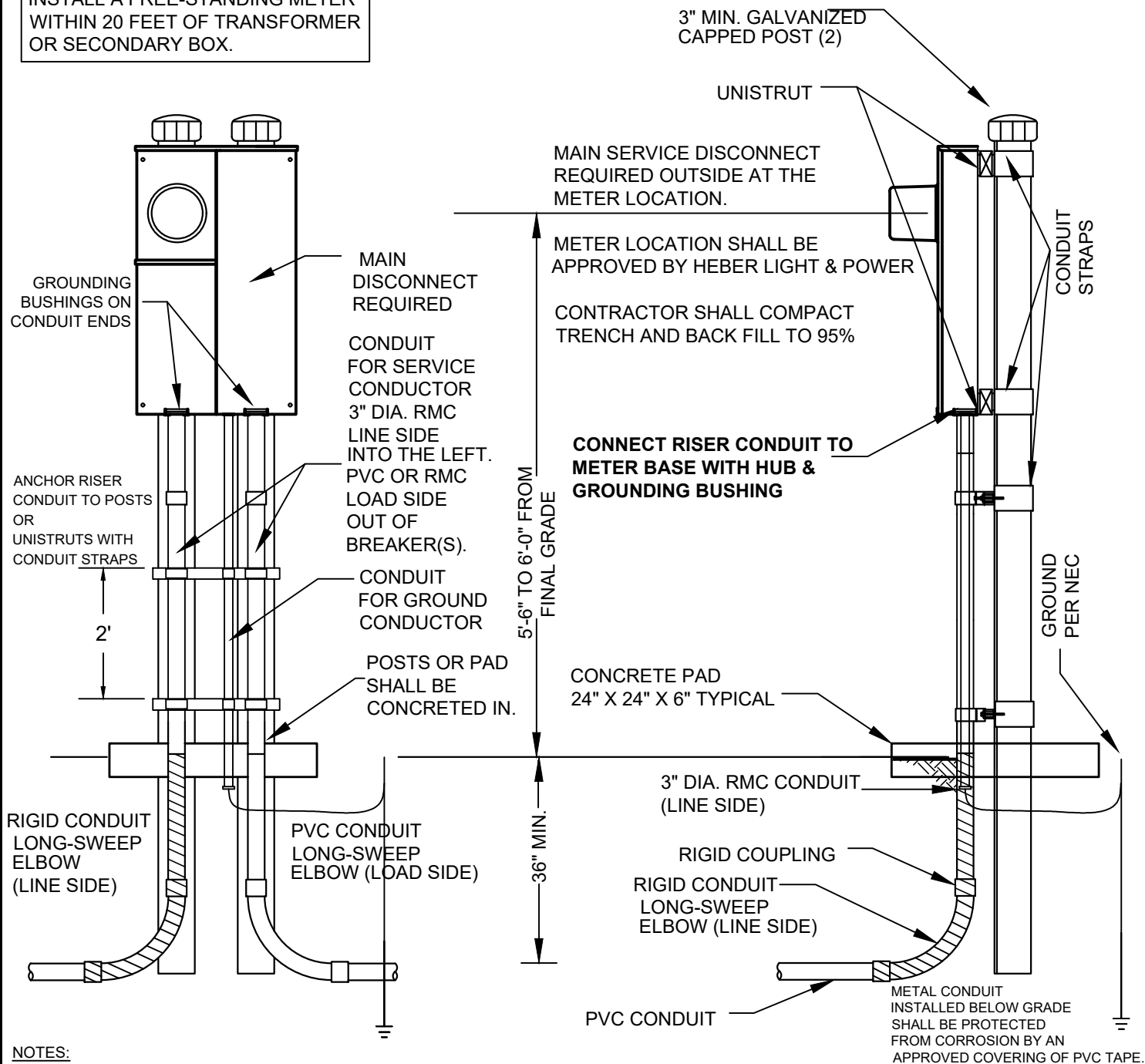

**NOTES:**

1. 100 AMP SERVICE MINIMUM SERVICE SIZE THAT CAN BE INSTALLED (NEC 310.12.)
2. DISTANCE FROM POWER SOURCE TO METER CANNOT EXCEED 20 FEET IN CABIN AREAS, WITH A MAXIMUM OF TWO 90 DEGREE ELBOWS, WITHOUT ADDITIONAL LINE EXTENSION.
3. PVC CONDUIT SHALL NOT BE HEATED TO MAKE BENDS. ONLY CONDUIT WITH FACTORY BENDS WILL BE ACCEPTED.
4. MULE TAPE SHALL BE PULLED BY OWNER THROUGH CONDUIT BEFORE CONDUCTOR WILL BE PULLED BY HEBER LIGHT & POWER.
5. SERVICE WILL NOT BE CONNECTED UNTIL HEBER LIGHT & POWER HAS INSPECTION REPORT FROM LOCAL MUNICIPALITY.



**REQUIREMENTS & STANDARDS**  
**FREE STANDING METER**  
**100-400 AMP (1 OR 3 PHASE)**

TYPICAL INSTALLATION

DWG: <b>3.2.3</b>
REV. 0.00
BY: JB/MA
DATE: 1/13/25

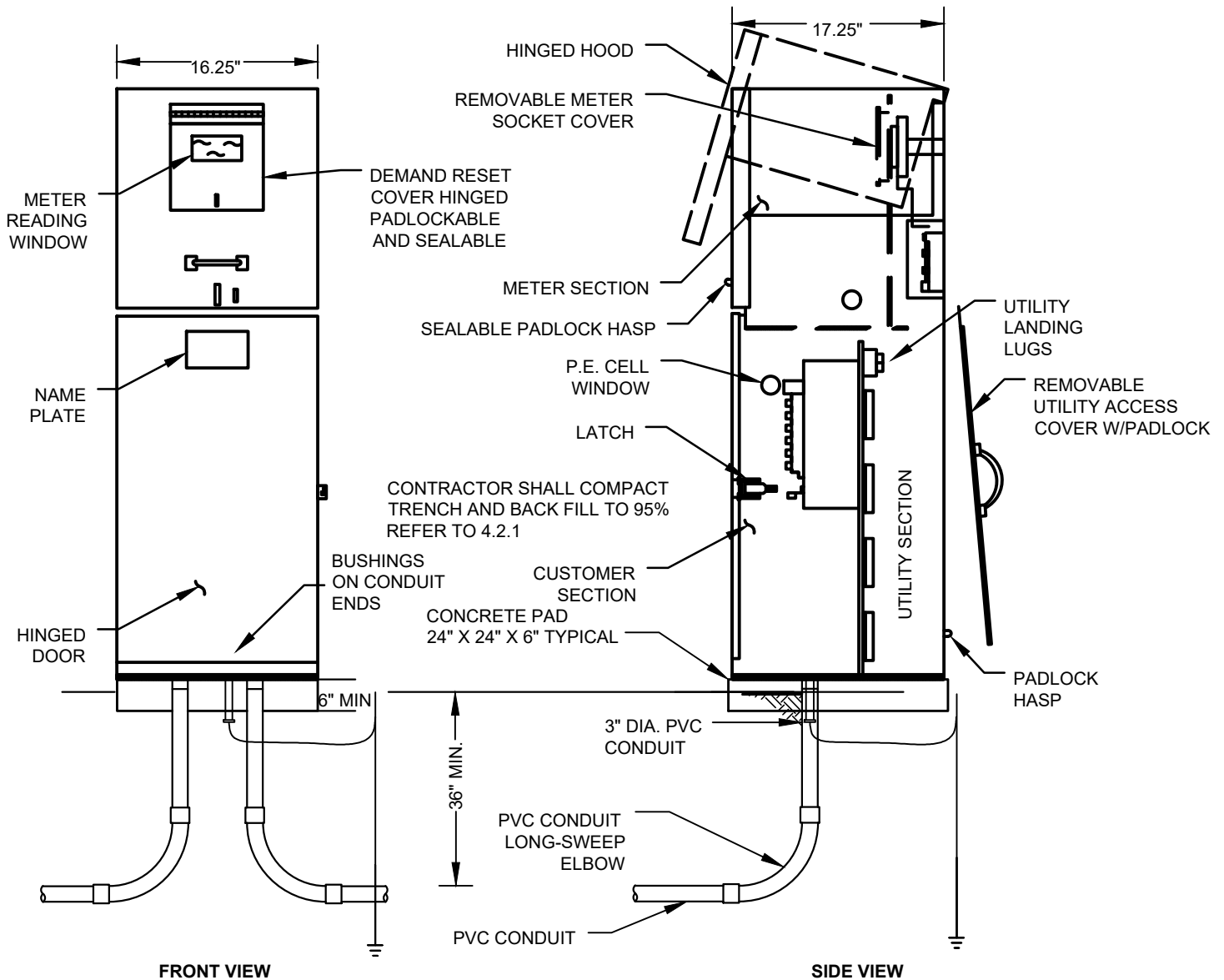

**NOTES:**

1. METER SOCKET: 100 AMPS OR 200 AMPS. 100 AMP SERVICE MINIMUM SIZE THAT CAN BE INSTALLED (NEC 310.12.)
2. METER SOCKET WITH TEST BLOCKS.
3. MAIN BREAKER: 100 AMP OR 200 AMP, 100K AIC.
4. UTILITY LANDING LUGS: 200 AMPS, 250 KCMIL.
5. 12-GAUGE CORROSION-RESISTANT ZINC-COATED STEEL CONSTRUCTION, HOOD AND COVERS 14-GAUGE.
6. RAINPROOF TYPE 3R ENCLOSURE.
7. COMPLIES WITH CALTRANS SPECIFICATION ES-2E.
8. MEETS EUSERC 308 REQUIREMENTS.
9. ALL FACTORY WIRING IS 600 VOLT RATED COPPER.
10. DISTANCE FROM POWER SOURCE TO METER CANNOT EXCEED 20 FEET IN CABIN AREAS WITH A MAXIMUM OF TWO 90 DEGREE ELBOWS, WITHOUT ADDITIONAL LINE EXTENSION.
11. PVC CONDUIT SHALL NOT BE HEATED TO MAKE BENDS. ONLY CONDUIT WITH FACTORY BENDS WILL BE ACCEPTED.
12. MULE TAPE SHALL BE PULLED BY OWNER THROUGH CONDUIT BEFORE CONDUCTOR WILL BE PULLED BY HEBER LIGHT & POWER.
13. SERVICE WILL NOT BE CONNECTED UNTIL HEBER LIGHT & POWER HAS INSPECTION REPORT FROM LOCAL MUNICIPALITY.



**REQUIREMENTS & STANDARDS**  
**PEDESTAL METER**  
**100-200 AMP (1 PHASE)**

**TYPICAL INSTALLATION**

DWG: **3.2.4**

REV. 0.00

BY: JB/MA

DATE: 1/13/25

NOTE FOR CABIN COMMUNITIES (SEE 3.2.3):  
INSTALL A FREE-STANDING METER WITHIN 20  
FEET OF TRANSFORMER OR SECONDARY BOX.

NOTE: CUSTOMER  
RESPONSIBLE FOR ALL  
CONDUCTOR AND  
SERVICE COMPONENTS  
FROM SERVICE MAST  
INTO HOUSE - METER  
PROVIDED AND OWNED  
BY HEBER LIGHT &  
POWER

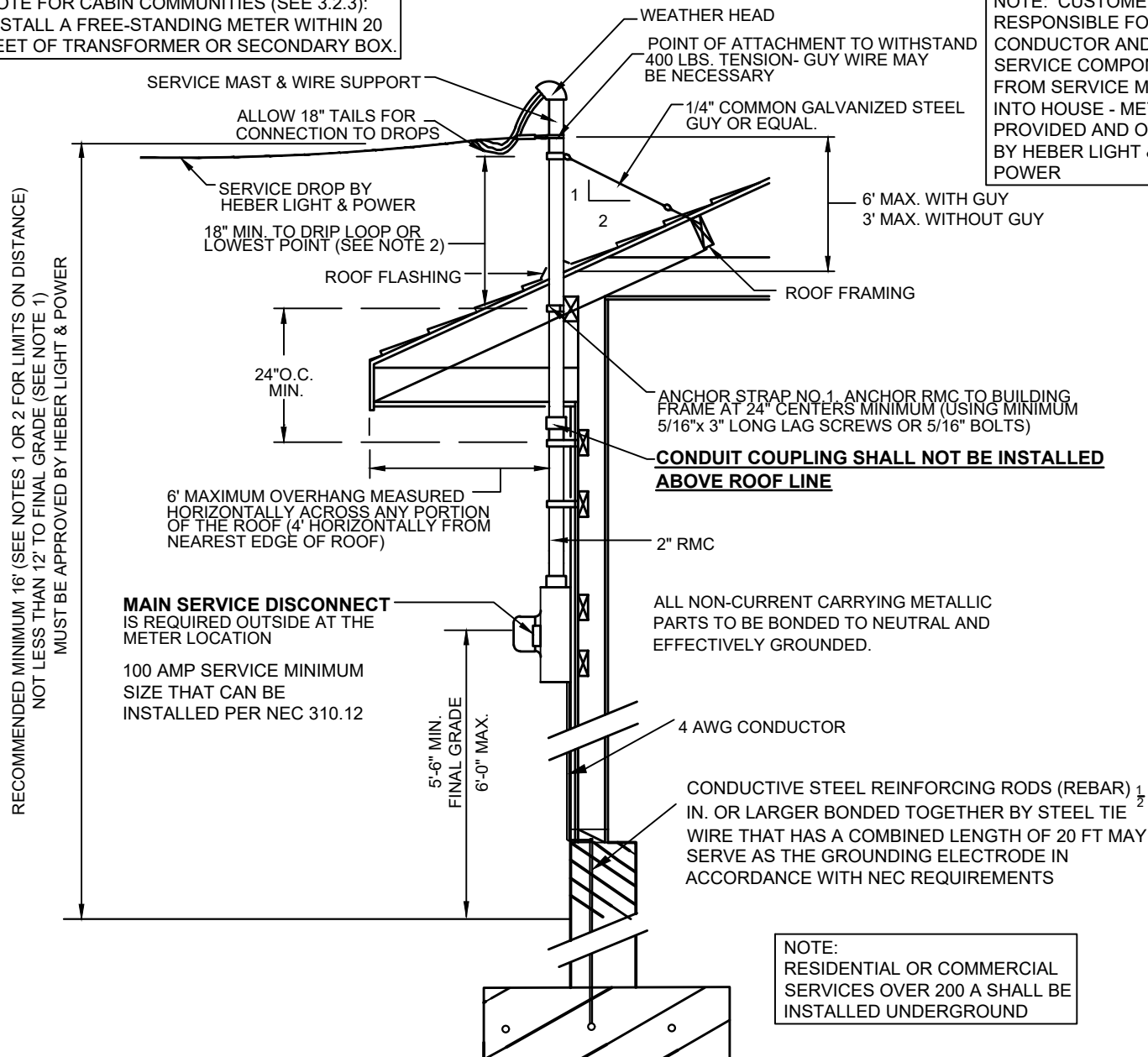

**NOTES:**

1. IF ACCESSIBLE TO TRUCK TRAFFIC, TO OTHER VEHICLES OVER 8' IN HEIGHT, OR TO RIDERS ON HORSEBACK, MINIMUM ATTACHMENT HEIGHT IS 16'; REFER TO NESC TABLE 232-1.
2. IF THE SERVICE IS CROSSING THE ROOF FOR MORE THAN 6' HORIZONTALLY IN ANY DIRECTION, OR MORE THAN 4' HORIZONTALLY FROM THE NEAREST EDGE OF THE ROOF, REFER TO NESC 234C3 FOR THE CLEARANCE.
3. FOR CLEARANCE OF SERVICE DROPS, SEE SECTION 230 OF THE NESC.
4. SERVICE MAST MUST BE MOUNTED ON SIDE NEAREST POLE, HEBER LIGHT & POWER & BUILDING INSPECTION TO APPROVE LOCATION.
5. SERVICE WILL NOT BE CONNECTED UNTIL HEBER LIGHT & POWER HAS INSPECTION REPORT FROM LOCAL MUNICIPALITY.
6. USE OXIDE INHIBITOR WHEN TERMINATING ALUMINUM CONDUCTORS.
7. HEBER LIGHT & POWER IS ONLY RESPONSIBLE UP TO CONNECTION POINT ON MAST.
8. CUSTOMER RESPONSIBLE FOR METER BASE, MAST, & WEATHERHEAD. ANY DAMAGE TO THESE SHALL BE PAID BY CUSTOMER.



**REQUIREMENTS & STANDARDS**  
**OVERHEAD SERVICE**  
**100-200 AMP (1 PHASE)**

RESIDENTIAL & COMMERCIAL POWER SERVICE

DWG: **3.2.5**

REV. 0.00

BY: JB/MA

DATE: 1/13/25

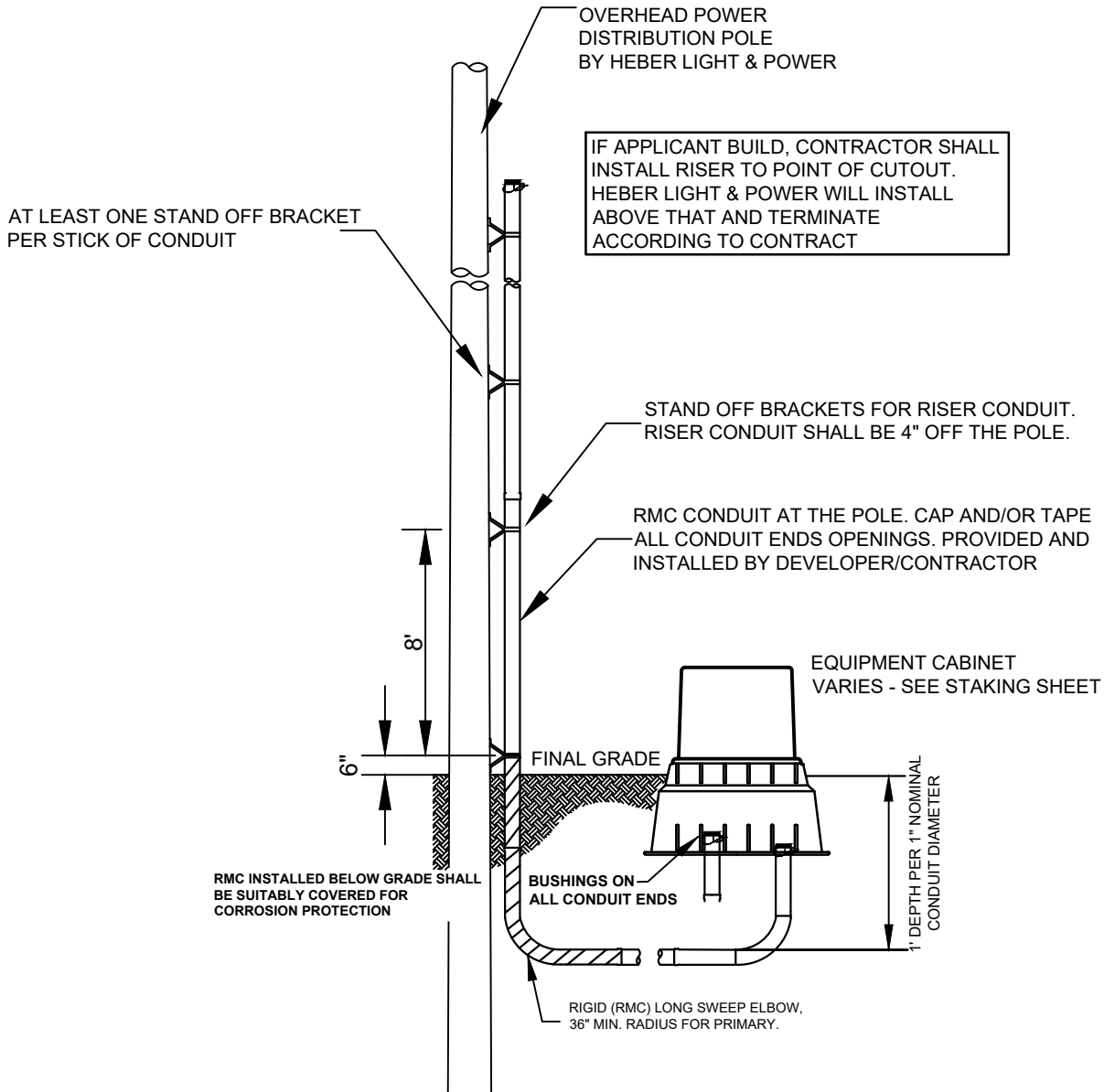

**NOTES:**

1. HEBER LIGHT & POWER SHALL PROVIDE AND SET POLE AND RISER; PROVIDE, PULL & TERMINATE CONDUCTORS.
2. EQUIPMENT BASE SHALL BE SET LEVEL AND ALIGNED WITH THE WALK OR ADJACENT ENTITIES TO PROVIDE A NEAT APPEARANCE.
3. CONDUIT AND EQUIPMENT SHALL BE PLACED AFTER CURB, GUTTER AND WALK TO ASSURE CORRECT PLACEMENT WITHIN THE EASEMENT.
4. FOR DEVELOPMENT WITHOUT WALKS, PLACE EQUIPMENT 5' MINIMUM 8' MAXIMUM BEHIND CURB.
5. PVC CONDUIT SHALL NOT BE HEATED TO MAKE BENDS. ONLY CONDUIT WITH FACTORY BENDS WILL BE ACCEPTED.



**REQUIREMENTS & STANDARDS**

**RISER POLE  
(OVERHEAD TO  
UNDERGROUND)  
(LOCATIONS IN THE P.U.E.)**

DWG: **3.3.1**

REV. 0.00

BY: JB/MA

DATE: 2/6/25



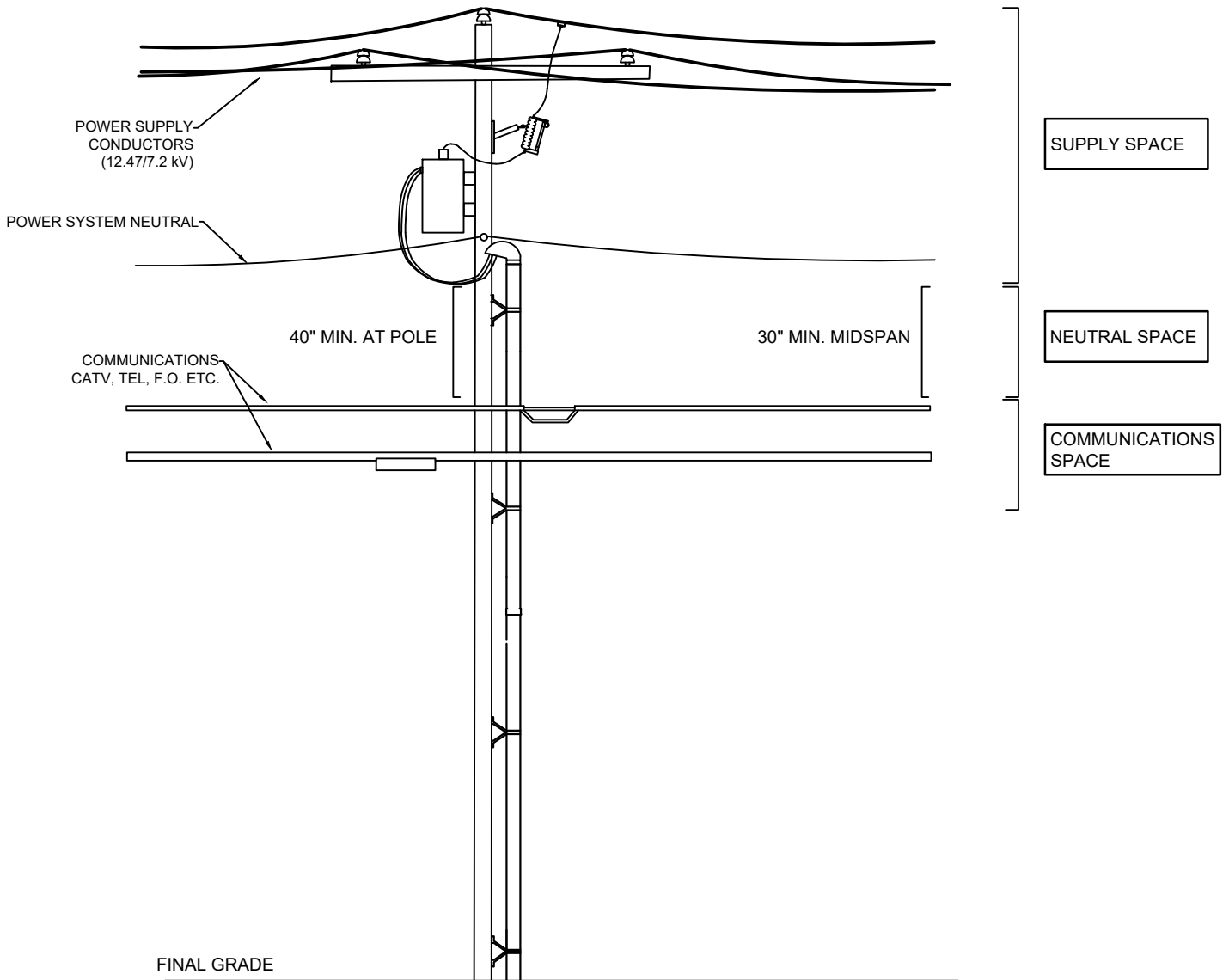

**NOTES:**

1. IF COMMUNICATION ATTACHMENTS DON'T MEET NESC CLEARANCES, COMMUNICATION COMPANY SHALL BE RESPONSIBLE TO PAY FOR UPGRADES.
2. AT THE POLE COMMUNICATIONS CONDUCTORS SHALL BE ATTACHED AT LEAST 40" BELOW THE LOWEST POWER SUPPLY POINT. THIS COULD BE A TRANSFORMER SECONDARY DRIP LOOP AS SHOWN HERE.
3. AT MIDSPAN COMMUNICATIONS CONDUCTORS SHALL BE AT LEAST 30" BELOW THE LOWEST SAG OF THE LOWEST POWER SUPPLY CONDUCTOR
4. COMMUNICATIONS CONDUCTORS SHALL BE ATTACHED TO PROVIDE FOR REQUIRED GROUND CLEARANCE (SEE NESC).



**REQUIREMENTS & STANDARDS**  
**COMMUNICATION SPACE**  
**& ATTACHMENT**  
**(OVERHEAD)**

DWG: **3.3.2**

REV. 0.00

BY: JB/MA

DATE: 2/6/25

CONTRACTOR WILL BE RESPONSIBLE FOR LEVELING EQUIPMENT BASES ONCE SETTLED IF THEY HAVE EXCAVATED UNDER OR WITHIN 2' OF EQUIPMENT.

STOP DIGGING 2' BEFORE HEBER LIGHT & POWER EQUIPMENT WITHOUT HEBER LIGHT & POWER PERSONNEL PRESENT.

**HDPE (BORE PIPE) NOTES:**

1. INSIDE PIPE SHALL BE BEVELED AT A 45 DEGREE ANGLE AT ALL FITTINGS & CONNECTIONS
2. HDPE ID SHALL MATCH AS CLOSE AS POSSIBLE TO PVC ID. CONTACT HEBER LIGHT & POWER FOR APPROVAL OF PROPOSED SOLUTION.
3. MULE TAPE SHALL BE INSTALLED

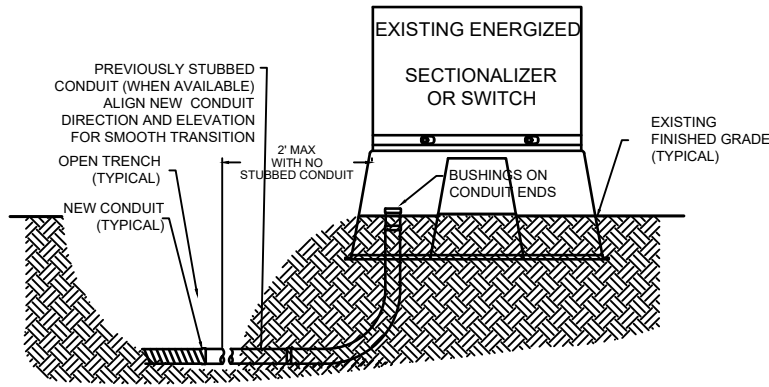

1 CONNECTING TO A SECTIONALIZER

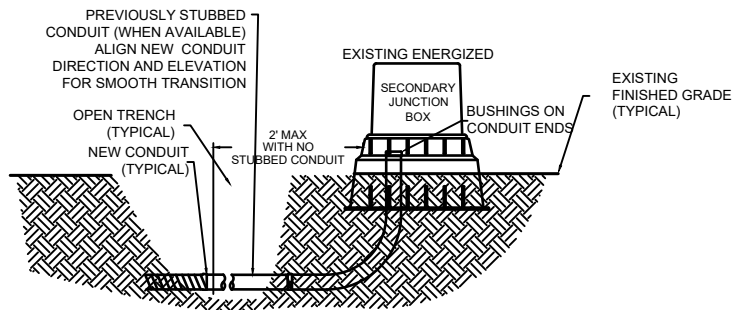

2 CONNECTING TO A SECONDARY JUNCTION BOX

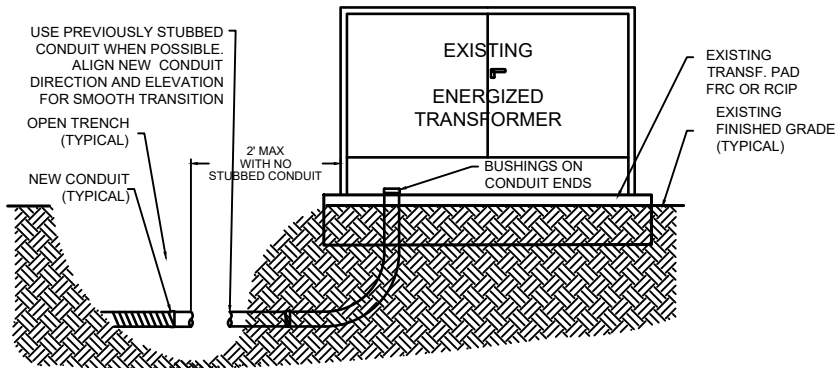

3 CONNECTING TO A TRANSFORMER

**NOTES:**

1. FOR SAFETY REASONS DO NOT INSTALL CONDUITS/CONDUCTORS INSIDE ENERGIZED EQUIPMENT. HEBER LIGHT & POWER PERSONNEL WILL OPEN THE BOX & HELP GET CONDUIT INTO THE RIGHT LOCATION WITHIN THE BOX.
2. STOP INSTALLATION OF CONDUITS/CONDUCTORS A MAXIMUM OF 2 FEET FROM ENERGIZED EQUIPMENT.
3. EXTEND TRENCH TO THE EDGE OF THE EQUIPMENT.
4. CONTRACTOR SHALL SUPPLY SWEEPS & ADDITIONAL CONDUIT REQUIRED TO COMPLETE THE INSTALLATION ASSISTED BY HEBER LIGHT & POWER.
5. CONTACT HEBER LIGHT & POWER TO SCHEDULE CREWS FOR INSTALLATION OF CONDUIT/CONDUCTORS INTO ENERGIZED EQUIPMENT.
6. ALL NEW CONDUIT RUNS SHALL BE INSTALLED BY CONTRACTOR INTO TRANSFORMER/SECONDARY JUNCTION BOX WITH HEBER LIGHT & POWER SUPERVISION.
7. BASES SHALL BE PLACED ON FULL DEPTH COMPACT ENGINEERED FILL - COMPACTED TO 95% MAX DENSITY. EXTEND COMPACTED BASE MATERIAL AS REQUIRED TO MAINTAIN STABLE SUPPORT. REFER TO 4.2.1
8. DEVELOPER/CONTRACTOR SHALL BE CHARGED FOR ALL BROKEN/DAMAGED EQUIPMENT UP TO THE TIME THE HOMEOWNER TAKES OCCUPANCY.



**REQUIREMENTS & STANDARDS**  
**CONNECTION DETAIL**  
**TO EXISTING**  
**ENERGIZED EQUIPMENT**  
**RESIDENTIAL & COMMERCIAL POWER SERVICE**

DWG: **4.1.0**

REV. 0.00

BY: JB/MA

DATE: 1/13/25

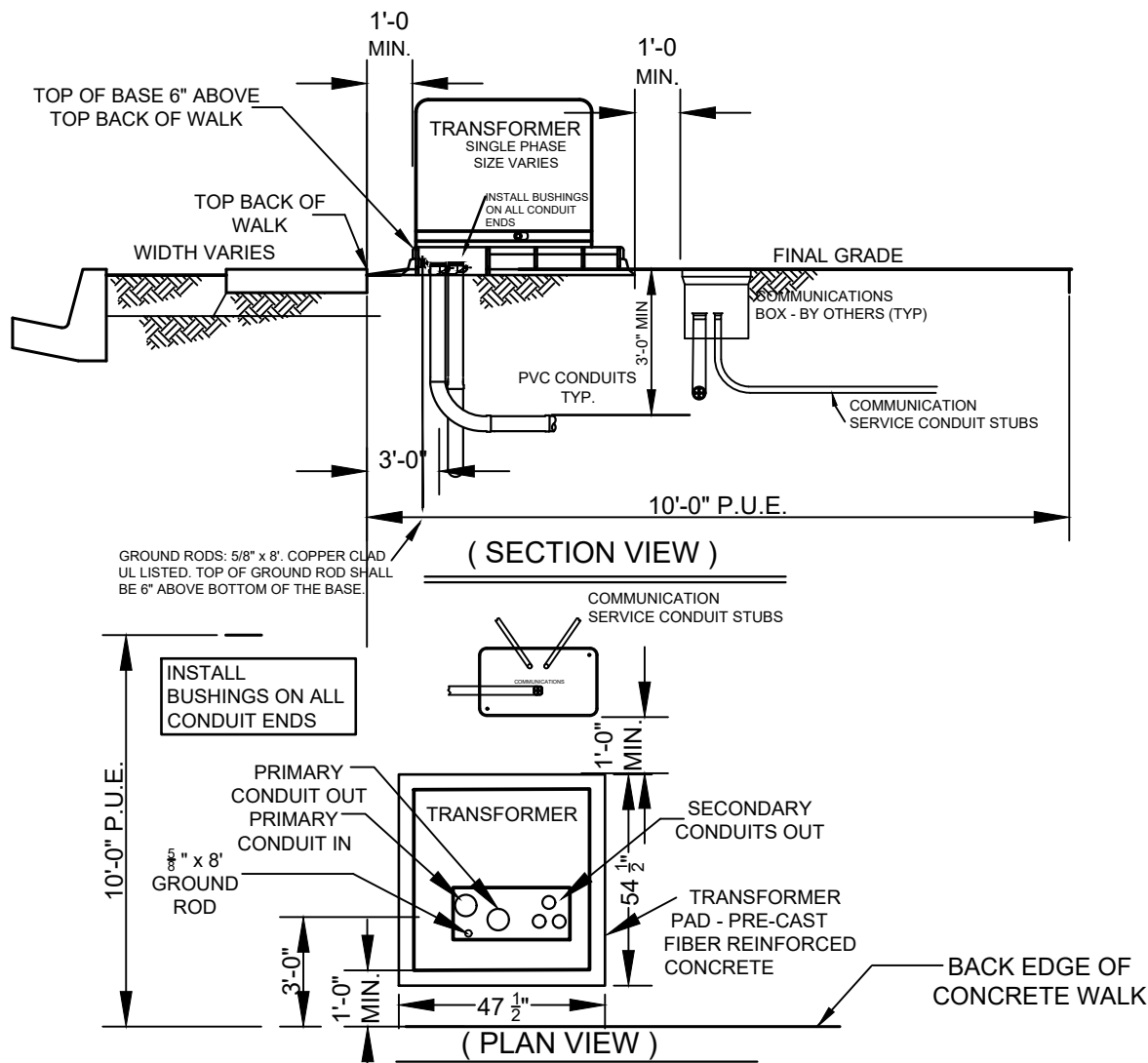

**NOTES:**

1. DEVELOPER/CONTRACTOR SHALL PROVIDE AND INSTALL ALL REQUIRED CONDUITS, AND GROUND RODS AS SHOWN ON THE STAKING SHEET.
2. CONTRACTOR SHALL CALL HEBER LIGHT & POWER FOR INSPECTION WHEN BASES HAVE BEEN SET.
3. TRANSFORMER BASES SHALL BE PROVIDED BY HEBER LIGHT & POWER AND INSTALLED BY DEVELOPER/ CONTRACTOR. TRANSFORMER BASES SHALL BE PRE-CAST FIBER REINFORCED CONCRETE.
4. SEE STAKING SHEET FOR EQUIPMENT LOCATIONS.
5. DO NOT OBSTRUCT ACCESS TO POWER BOXES; MAINTAIN 3' CLEAR EXCEPT AS NOTED. PROVIDE 10' CLEARANCE ON CABINET ACCESS SIDES.
6. HEBER LIGHT & POWER SHALL PROVIDE AND SET TRANSFORMERS; PROVIDE, PULL & TERMINATE CONDUCTORS
7. CONTRACTOR SHALL PLACE BASES AND BOXES ON FULL DEPTH COMPACT ENGINEERED FILL - COMPACTED TO 95% MAX DENSITY. EXTEND BASE MATERIAL AS REQUIRED TO MAINTAIN STABLE SUPPORT. REFER TO 4.2.1
8. EQUIPMENT BASES SHALL BE SET LEVEL AND ALIGNED WITH THE WALK OR ADJACENT ENTITIES TO PROVIDE A NEAT APPEARANCE.
9. CONDUIT AND EQUIPMENT SHALL BE PLACED AFTER CURB, GUTTER AND WALK TO ASSURE CORRECT PLACEMENT VERTICALLY AND HORIZONTALLY WITHIN THE EASEMENT.
10. FOR DEVELOPMENT WITHOUT WALKS, PLACE EQUIPMENT 5' MINIMUM 8' MAXIMUM BEHIND CURB.
11. DEVELOPER/CONTRACTOR SHALL BE CHARGED FOR ALL BROKEN/DAMAGED EQUIPMENT UP TO THE TIME THE HOMEOWNER TAKES OCCUPANCY.



**REQUIREMENTS & STANDARDS**

**TRANSFORMER  
SINGLE PHASE**

**(LOCATIONS IN THE P.U.E.)**

DWG: **4.1.1**

REV. 0.00

BY: JB/MA

DATE: 1/13/25

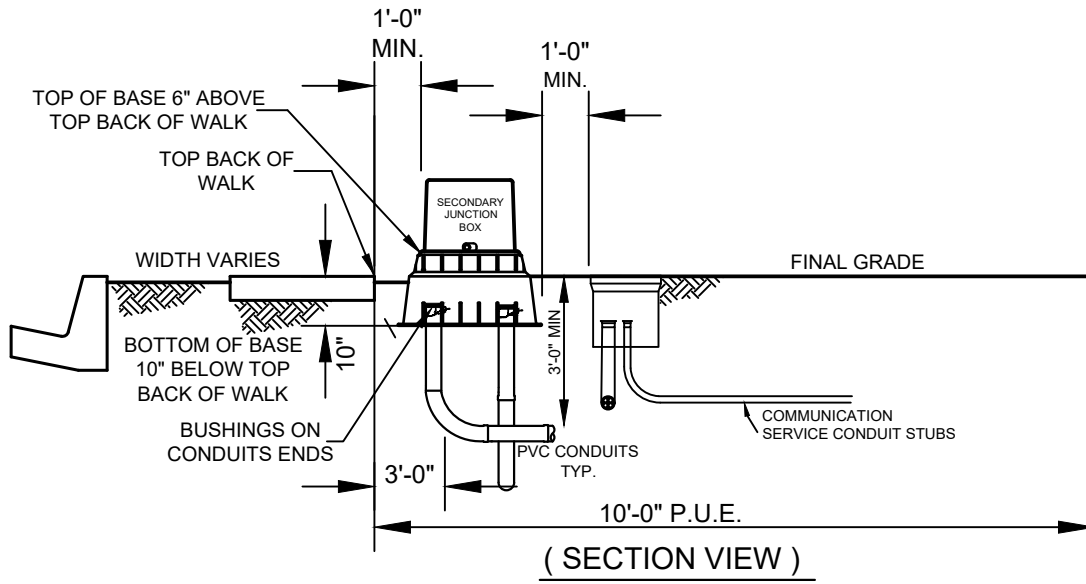

FOLLOW LOCAL MUNICIPALITIES STREETLIGHT SPECIFICATIONS. HEBER LIGHT & POWER PROVIDES POWER SOURCE, FUSE, AND PHOTOCCELL ONLY. DEVELOPER TO PROVIDE POLE, HEAD, BASE, AND WIRING INTO POWER SOURCE.

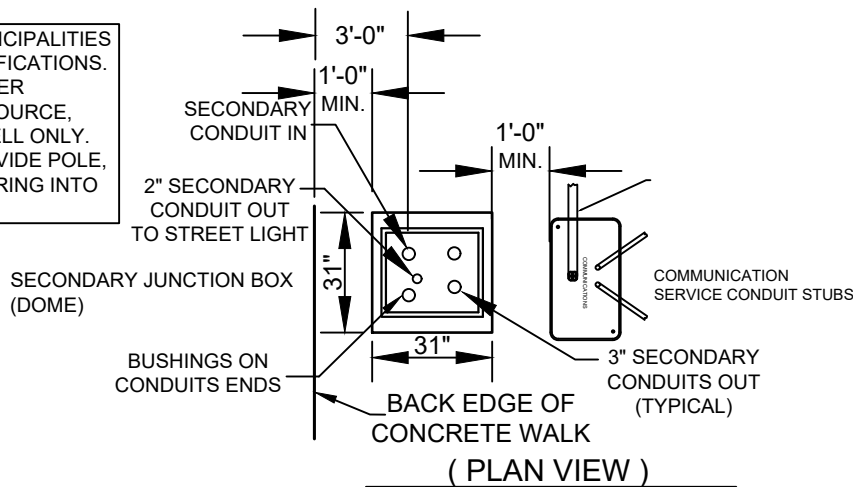

**NOTES:**

1. DEVELOPER/CONTRACTOR SHALL PROVIDE AND INSTALL ALL REQUIRED CONDUITS, AS SHOWN ON THE STAKING SHEET.
2. SECONDARY JUNCTION BOXES SHALL BE PROVIDED BY HEBER LIGHT & POWER AND INSTALLED BY DEVELOPER/CONTRACTOR. CONTRACTOR SHALL CALL HEBER LIGHT & POWER FOR INSPECTION WHEN BASES HAVE BEEN SET.
3. SEE STAKING SHEET FOR EQUIPMENT LOCATIONS.
4. DO NOT OBSTRUCT ACCESS TO POWER BOXES; MAINTAIN 3' CLEAR EXCEPT AS NOTED. PROVIDE 10' CLEARANCE ON CABINET ACCESS SIDES.
5. HEBER LIGHT & POWER SHALL PROVIDE, PULL & TERMINATE CONDUCTORS UP TO SECONDARY BOX.
6. BASES AND BOXES SHALL BE PLACED ON FULL DEPTH COMPACT ENGINEERED FILL - COMPACTED TO 95% MAX DENSITY. EXTEND COMPACTED BASE MATERIAL AS REQUIRED TO MAINTAIN STABLE SUPPORT. REFER TO 4.2.1
7. EQUIPMENT BASES SHALL BE SET LEVEL AND ALIGNED WITH THE WALK OR ADJACENT ENTITIES TO PROVIDE A NEAT APPEARANCE.
8. CONDUIT AND EQUIPMENT SHALL BE PLACED AFTER CURB, GUTTER AND WALK TO ASSURE CORRECT PLACEMENT VERTICALLY AND HORIZONTALLY WITHIN THE EASEMENT.
9. FOR DEVELOPMENT WITHOUT WALKS, PLACE EQUIPMENT 5' MINIMUM 8' MAXIMUM BEHIND CURB.
10. DEVELOPER/CONTRACTOR SHALL BE CHARGED FOR ALL BROKEN/DAMAGED EQUIPMENT UP TO THE TIME THE HOMEOWNER TAKES OCCUPANCY.



**REQUIREMENTS & STANDARDS**  
**SECONDARY**  
**JUNCTION BOX**  
**(SECONDARY PEDESTAL)**  
**(LOCATIONS IN THE P.U.E.)**

DWG: **4.1.2**

REV. 0.00

BY: JB/MA

DATE: 2/4/25



INSTALL SWITCHGEAR WITH WIDE SIDE (DOORS) PARALLEL TO THE SIDEWALK AND ROAD

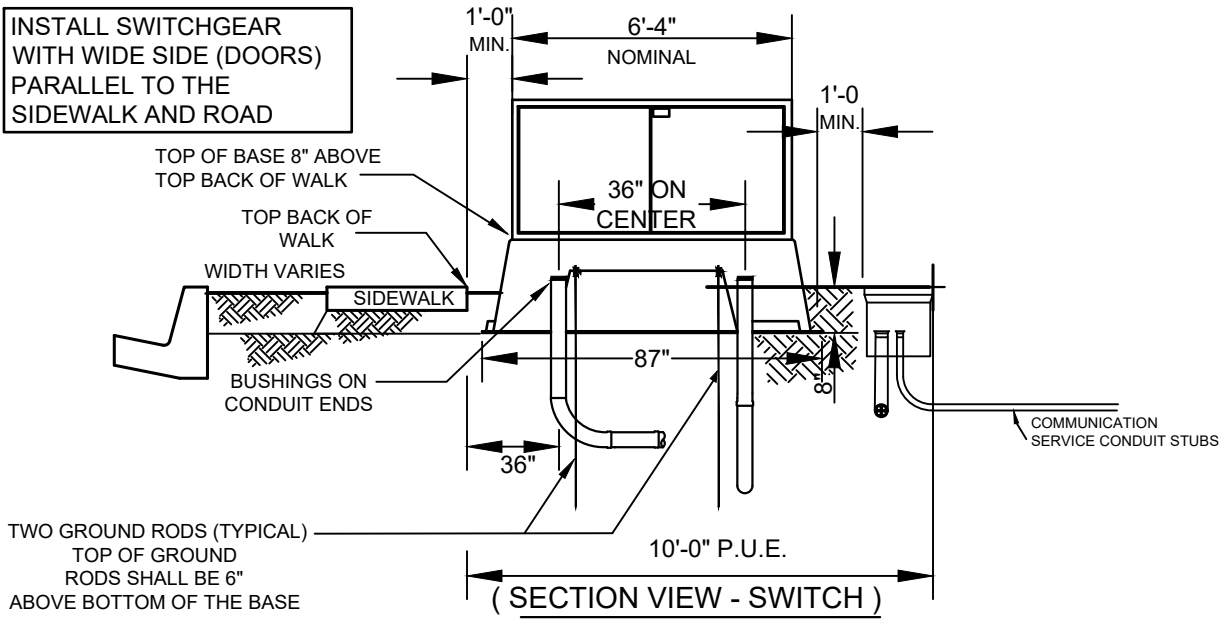

( SECTION VIEW - SWITCH )

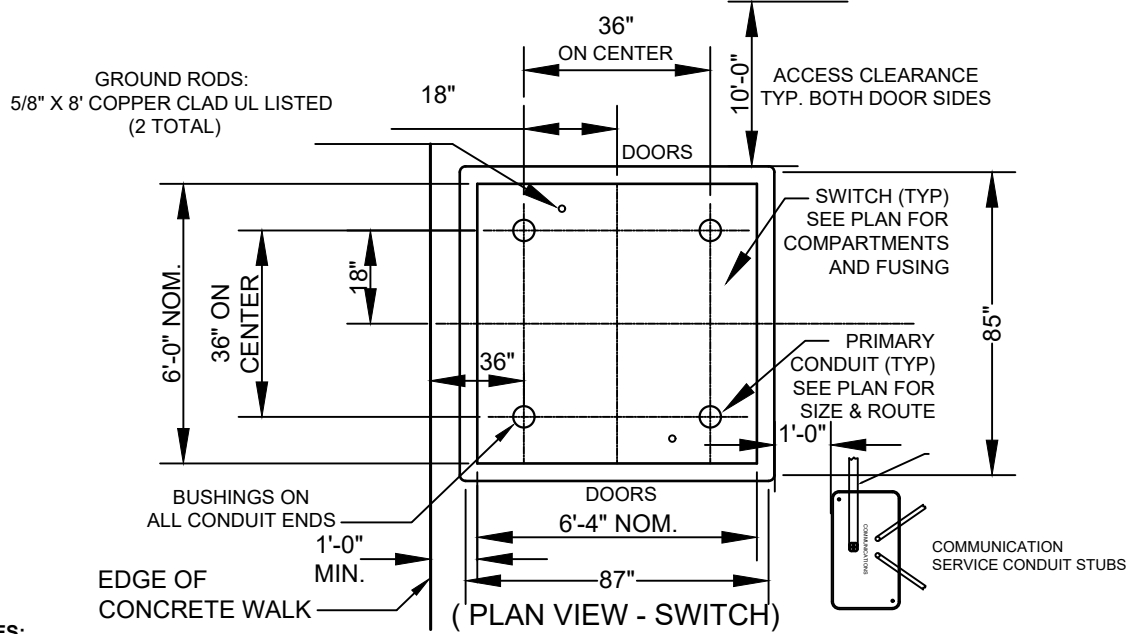

( PLAN VIEW - SWITCH )

- NOTES:**
1. DEVELOPER/CONTRACTOR SHALL PROVIDE AND INSTALL ALL CONDUITS AND GROUND RODS
  2. HEBER LIGHT & POWER SHALL PROVIDE EQUIPMENT BASES TO BE INSTALLED BY DEVELOPER/CONTRACTOR. CALL HEBER LIGHT & POWER FOR INSPECTION WHEN BASES ARE SET.
  3. BASES SHALL BE PLACED ON FULL DEPTH COMPACT ENGINEERED FILL - COMPACTED TO 95% MAX DENSITY. EXTEND COMPACTED BASE MATERIAL AS REQUIRED TO MAINTAIN STABLE SUPPORT. REFER TO 4.2.1
  4. SEE STAKING SHEET FOR EQUIPMENT LOCATIONS.
  5. DO NOT OBSTRUCT ACCESS TO POWER BOXES; MAINTAIN 3' MINIMUM CLEARANCE EXCEPT AS NOTED.
  6. PROVIDE 10' CLEARANCE ON CABINET ACCESS SIDES (DOOR SIDES, PARALLEL TO SIDEWALK AND ROADS).
  7. HEBER LIGHT & POWER SHALL PROVIDE AND SET CABINETS; PROVIDE, PULL & TERMINATE CONDUCTORS
  8. EQUIPMENT BASE SHALL BE SET LEVEL AND ALIGNED WITH THE WALK OR ADJACENT ENTITIES
  9. CONDUIT AND EQUIPMENT BASES SHALL BE PLACED AFTER CURB, GUTTER AND WALK TO ASSURE CORRECT PLACEMENT WITHIN THE EASEMENT.
  10. DEVELOPER/CONTRACTOR SHALL BE CHARGED FOR ALL BROKEN/DAMAGED EQUIPMENT UP TO THE TIME HEBER LIGHT & POWER TAKES OWNERSHIP.
  11. PVC CONDUIT SHALL NOT BE HEATED TO MAKE BENDS. ONLY CONDUIT WITH FACTORY BENDS WILL BE ACCEPTED.



**REQUIREMENTS & STANDARDS**  
**PME SWITCHGEAR**  
**(LOCATIONS IN THE P.U.E.)**

DWG: <b>4.1.4</b>
REV. 0.00
BY: JB/MA
DATE: 2/6/25



**DEVELOPER IS RESPONSIBLE TO PROVIDE 10' MINIMUM CLEARANCE FROM TRANSFORMERS TO ANY COMBUSTIBLE BUILDING STRUCTURE. SEE DET. 5.3**

SEE WORK ORDER STAKING SHEET FOR TRANSFORMER SIZES AND OTHER EQUIPMENT LOCATIONS

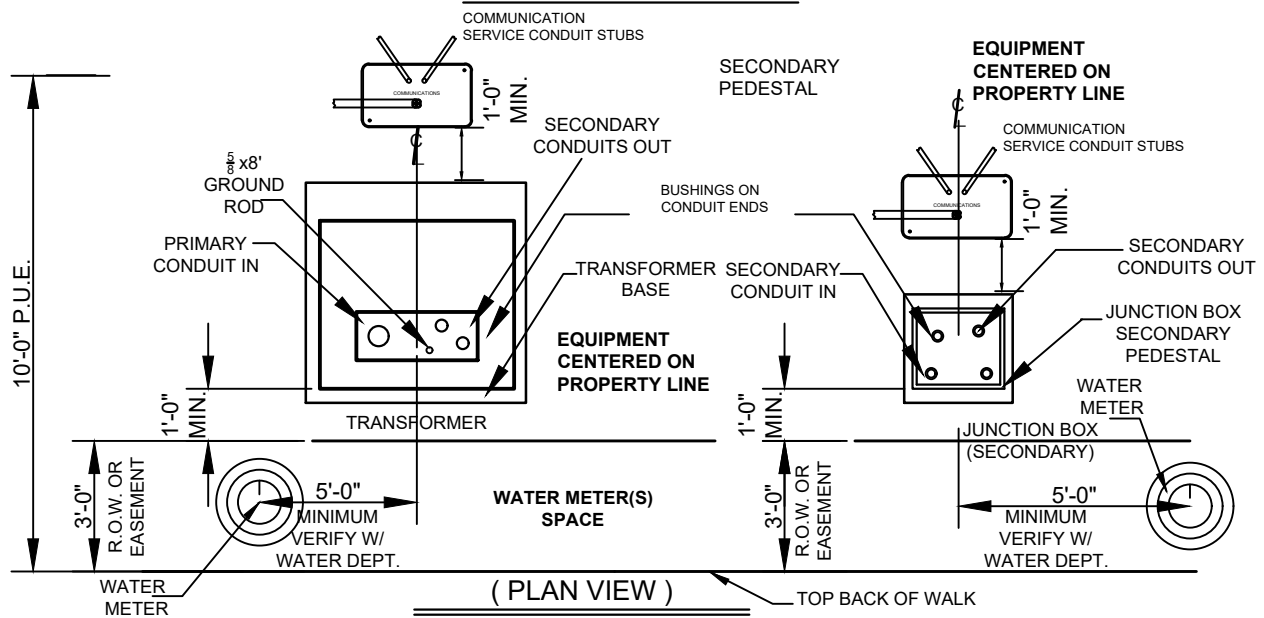
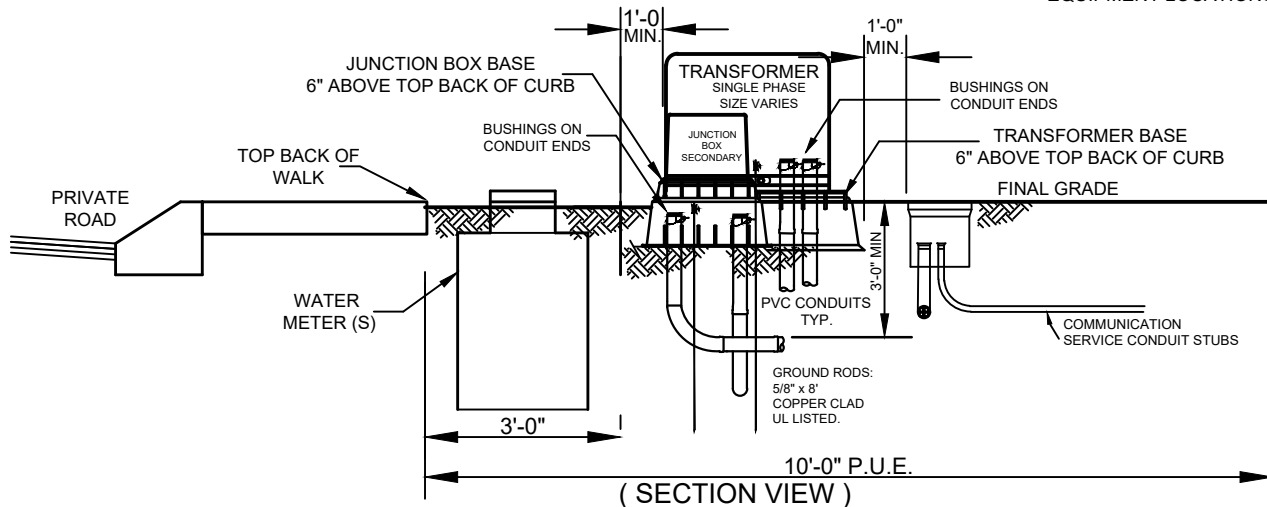

**NOTES:**

1. DEVELOPER/CONTRACTOR SHALL PROVIDE AND INSTALL CONDUITS AND GROUND RODS
2. HEBER LIGHT & POWER SHALL PROVIDE TRANSFORMER BASES AND SECONDARY JUNCTION BOXES, TO BE INSTALLED BY DEVELOPER/CONTRACTOR.
3. SEE STAKING SHEET FOR EQUIPMENT LOCATIONS. EQUIPMENT SHALL BE CENTERED ON LOT LINES TO THE EXTENT POSSIBLE. OTHER LOCATIONS AS REQUIRED AND APPROVED BY HEBER LIGHT & POWER.
4. DO NOT OBSTRUCT ACCESS TO POWER BOXES; MAINTAIN 3' CLEAR EXCEPT AS NOTED. PROVIDE 10' CLEARANCE ON ALL CABINET ACCESS SIDES.
5. HEBER LIGHT & POWER SHALL PROVIDE AND SET TRANSFORMERS; PROVIDE, PULL & TERMINATE CONDUCTORS
6. BASES SHALL BE PLACED ON FULL DEPTH COMPACT ENGINEERED FILL - COMPACTED TO 95% MAX DENSITY. EXTEND COMPACTED BASE MATERIAL AS REQUIRED TO MAINTAIN STABLE SUPPORT. REFER TO 4.2.1
7. EQUIPMENT BASES SHALL BE SET LEVEL AND ALIGNED WITH THE WALK OR ADJACENT ENTITIES TO PROVIDE A NEAT APPEARANCE.
8. CONDUIT AND EQUIPMENT SHALL BE PLACED AFTER CURB AND WALK, TO ASSURE CORRECT PLACEMENT WITHIN THE EASEMENT.
9. PVC CONDUIT SHALL NOT BE HEATED TO MAKE BENDS. ONLY CONDUIT WITH FACTORY BENDS WILL BE ACCEPTED.



**REQUIREMENTS & STANDARDS**  
**TRANSFORMER,**  
**JUNCTION BOX &**  
**P.U.E. LOCATION**  
**(DEVELOPMENT WITH COMBO CURB/WALK)**

DWG: **4.1.5**

REV. 0.00

BY: JB/MA

DATE: 2/7/25

DEVELOPER IS RESPONSIBLE TO PROVIDE 10' MINIMUM CLEARANCE FROM TRANSFORMERS TO ANY COMBUSTIBLE BUILDING STRUCTURE. SEE DET. 5.3

SEE WORK ORDER STAKING SHEET FOR TRANSFORMER SIZES AND OTHER EQUIPMENT LOCATIONS

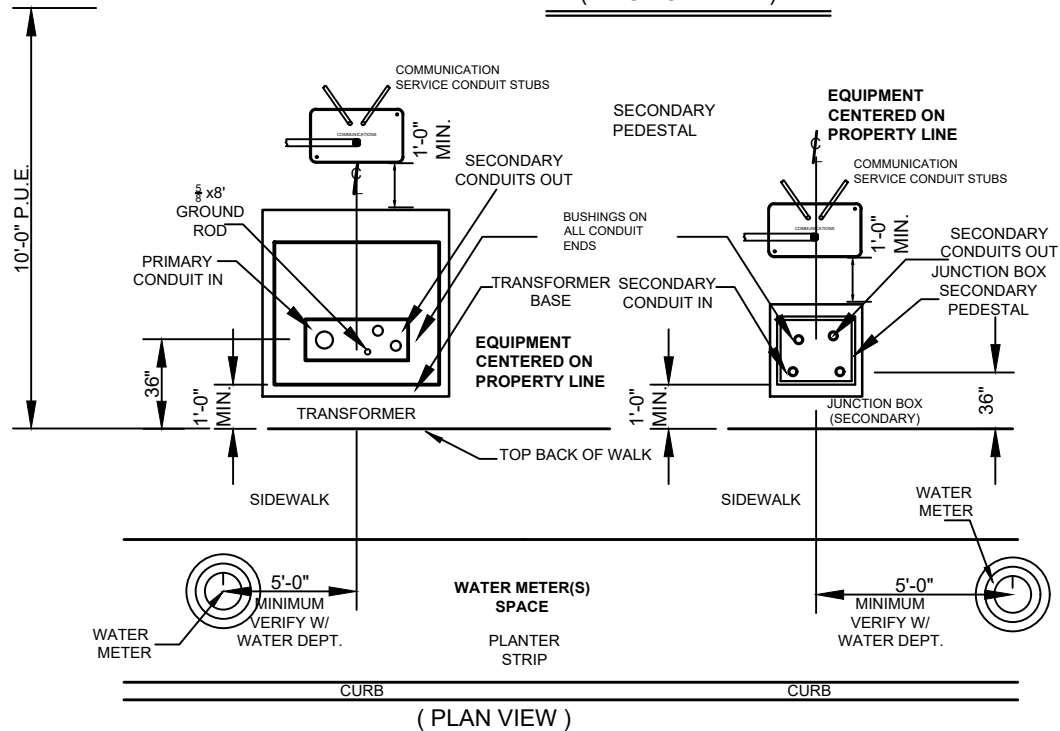
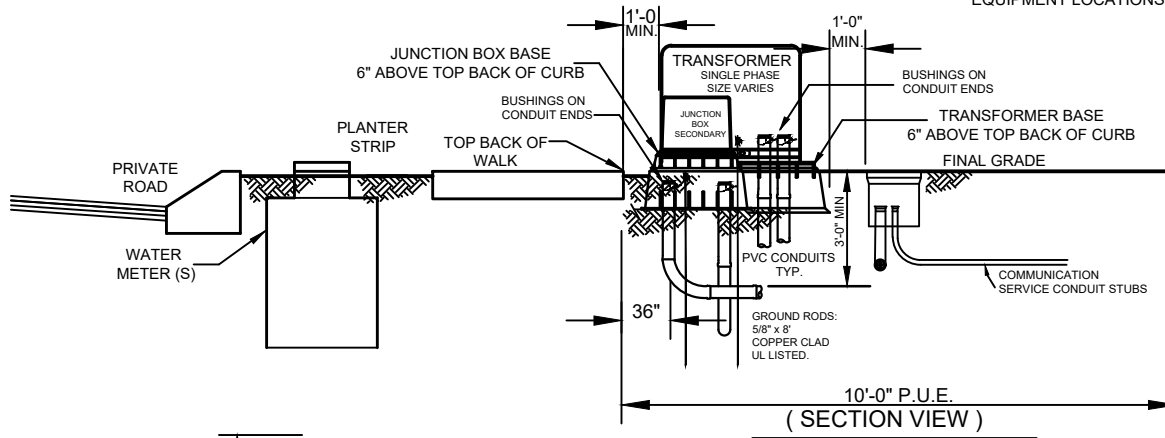

**NOTES:**

1. DEVELOPER/CONTRACTOR SHALL PROVIDE AND INSTALL CONDUITS AND GROUND RODS
2. HEBER LIGHT & POWER SHALL PROVIDE TRANSFORMER BASES AND SECONDARY JUNCTION BOXES, TO BE INSTALLED BY DEVELOPER/CONTRACTOR.
3. SEE STAKING SHEET FOR EQUIPMENT LOCATIONS. EQUIPMENT SHALL BE CENTERED ON LOT LINES TO THE EXTENT POSSIBLE. OTHER LOCATIONS AS REQUIRED AND APPROVED BY HEBER LIGHT & POWER.
4. DO NOT OBSTRUCT ACCESS TO POWER BOXES; MAINTAIN 3' CLEAR EXCEPT AS NOTED. PROVIDE 10' CLEARANCE ON ALL CABINET ACCESS SIDES.
5. HEBER LIGHT & POWER SHALL PROVIDE AND SET TRANSFORMERS; PROVIDE, PULL & TERMINATE CONDUCTORS
6. BASES SHALL BE PLACED ON FULL DEPTH COMPACT ENGINEERED FILL - COMPACTED TO 95% MAX DENSITY. EXTEND COMPACTED BASE MATERIAL AS REQUIRED TO MAINTAIN STABLE SUPPORT. REFER TO 4.2.1
7. EQUIPMENT BASES SHALL BE SET LEVEL AND ALIGNED WITH THE WALK OR ADJACENT ENTITIES TO PROVIDE A NEAT APPEARANCE.
8. CONDUIT AND EQUIPMENT SHALL BE PLACED AFTER CURB AND WALK, TO ASSURE CORRECT PLACEMENT WITHIN THE EASEMENT.
9. PVC CONDUIT SHALL NOT BE HEATED TO MAKE BENDS. ONLY CONDUIT WITH FACTORY BENDS WILL BE ACCEPTED.



**REQUIREMENTS & STANDARDS**  
**TRANSFORMER,**  
**JUNCTION BOX &**  
**P.U.E. LOCATION**  
**(DEVELOPMENT WITH CURB, PLANTER STRIP & WALK)**

DWG: **4.1.6**

REV. 0.00

BY: JB/MA

DATE: 2/7/25

**DEVELOPER IS RESPONSIBLE TO PROVIDE 10' MINIMUM CLEARANCE FROM TRANSFORMERS TO ANY COMBUSTIBLE BUILDING STRUCTURE. SEE DET. 5.3**

TYPICAL COVER OVER UTILITIES

- \*POWER – Secondary 48" Primary 48"– 72"
- \*GAS – 36"
- \*COMMUNICATIONS – Follows Power
- \*SANITARY SEWER – Varies
- \*CULINARY WATER – 60"
- \*SECONDARY WATER – 48"
- \*STORM DRAIN MIN. – Varies

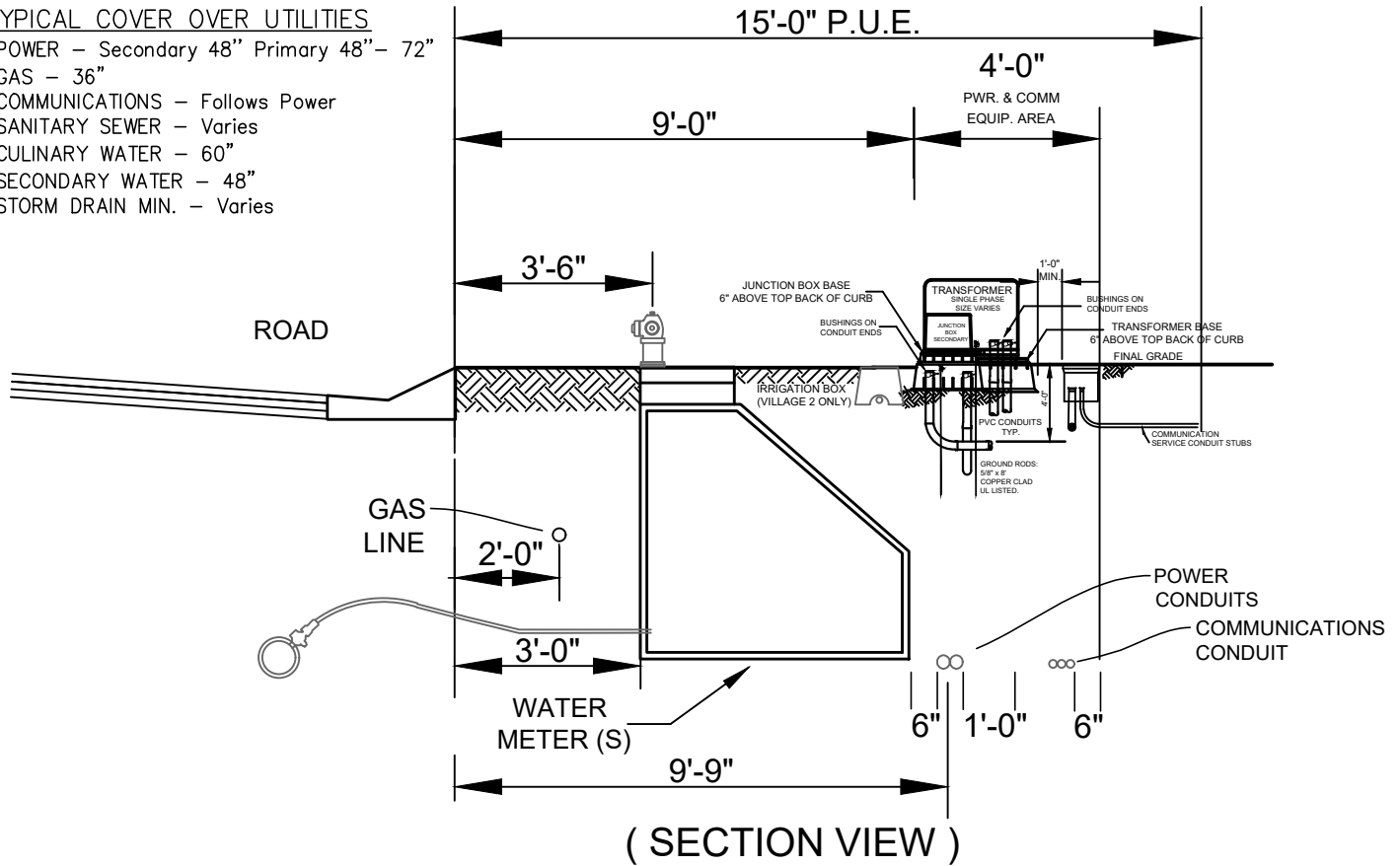

**NOTES:**

1. DEVELOPER/CONTRACTOR SHALL PROVIDE AND INSTALL CONDUITS AND GROUND RODS
2. HEBER LIGHT & POWER SHALL PROVIDE TRANSFORMER BASES AND SECONDARY JUNCTION BOXES, TO BE INSTALLED BY DEVELOPER/CONTRACTOR.
3. SEE STAKING SHEET FOR EQUIPMENT LOCATIONS. EQUIPMENT SHALL BE CENTERED ON LOT LINES TO THE EXTENT POSSIBLE. OTHER LOCATIONS AS REQUIRED AND APPROVED BY HEBER LIGHT & POWER.
4. DO NOT OBSTRUCT ACCESS TO POWER BOXES; MAINTAIN 3' CLEAR. PROVIDE 10' CLEARANCE ON ALL CABINET ACCESS SIDES.
5. HEBER LIGHT & POWER SHALL PROVIDE AND SET TRANSFORMERS; PROVIDE, PULL & TERMINATE CONDUCTORS
6. BASES SHALL BE PLACED ON FULL DEPTH COMPACT ENGINEERED FILL - COMPACTED TO 95% MAX DENSITY. EXTEND COMPACTED BASE MATERIAL AS REQUIRED TO MAINTAIN STABLE SUPPORT. REFER TO 4.2.1
7. EQUIPMENT BASES SHALL BE SET LEVEL AND ALIGNED WITH THE WALK OR ADJACENT ENTITIES TO PROVIDE A NEAT APPEARANCE.
8. CONDUIT AND EQUIPMENT SHALL BE PLACED AFTER CURB AND WALK, TO ASSURE CORRECT PLACEMENT WITHIN THE EASEMENT.
9. PVC CONDUIT SHALL NOT BE HEATED TO MAKE BENDS. ONLY CONDUIT WITH FACTORY BENDS WILL BE ACCEPTED.



**REQUIREMENTS & STANDARDS  
EQUIPMENT & SPECIAL  
P.U.E. LOCATION  
(15' PUE)  
(DEVELOPMENT WITH CURB & 15' PUE)**

DWG: **4.1.7**

REV. 0.00

BY: JB/MA

DATE: 2/7/25

**DEVELOPER IS RESPONSIBLE TO PROVIDE 10' MINIMUM CLEARANCE FROM TRANSFORMERS TO ANY COMBUSTIBLE BUILDING STRUCTURE. SEE DET. 5.3**

SEE WORK ORDER STAKING SHEET FOR TRANSFORMER SIZES AND OTHER EQUIPMENT LOCATIONS

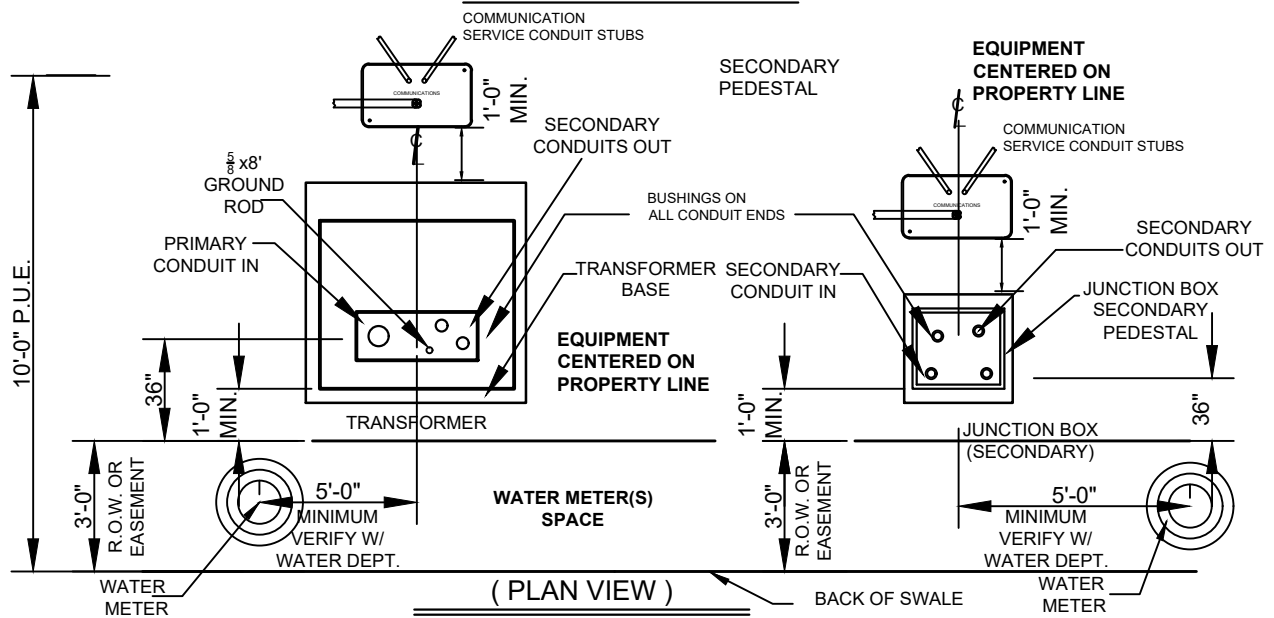
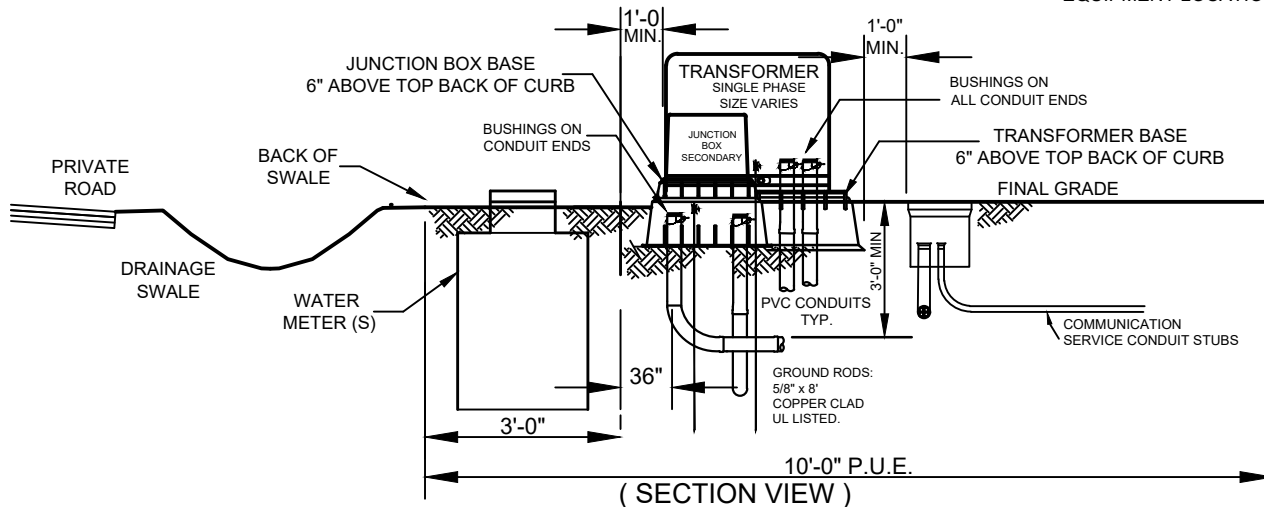

**NOTES:**

1. DEVELOPER/CONTRACTOR SHALL PROVIDE AND INSTALL CONDUITS AND GROUND RODS
2. HEBER LIGHT & POWER SHALL PROVIDE TRANSFORMER BASES AND SECONDARY JUNCTION BOXES, TO BE INSTALLED BY DEVELOPER/CONTRACTOR.
3. SEE STAKING SHEET FOR EQUIPMENT LOCATIONS. EQUIPMENT SHALL BE CENTERED ON LOT LINES TO THE EXTENT POSSIBLE. OTHER LOCATIONS AS REQUIRED AND APPROVED BY HEBER LIGHT & POWER.
4. DO NOT OBSTRUCT ACCESS TO POWER BOXES; MAINTAIN 3' CLEAR. PROVIDE 10' CLEARANCE ON ALL CABINET ACCESS SIDES.
5. HEBER LIGHT & POWER SHALL PROVIDE AND SET TRANSFORMERS; PROVIDE, PULL & TERMINATE CONDUCTORS
6. BASES SHALL BE PLACED ON FULL DEPTH COMPACT ENGINEERED FILL - COMPACTED TO 95% MAX DENSITY. EXTEND COMPACTED BASE MATERIAL AS REQUIRED TO MAINTAIN STABLE SUPPORT. REFER TO 4.2.1
7. EQUIPMENT BASES SHALL BE SET LEVEL AND ALIGNED WITH THE ROAD OR ADJACENT ENTITIES TO PROVIDE A NEAT APPEARANCE.
8. CONDUIT AND EQUIPMENT SHALL BE PLACED AFTER SURVEY, TO ASSURE CORRECT PLACEMENT WITHIN THE EASEMENT.
9. PVC CONDUIT SHALL NOT BE HEATED TO MAKE BENDS. ONLY CONDUIT WITH FACTORY BENDS WILL BE ACCEPTED.



**REQUIREMENTS & STANDARDS**  
**TRANSFORMER,**  
**JUNCTION BOX &**  
**P.U.E. LOCATION**  
**(DEVELOPMENT WITH SWALE, NO CURB)**

DWG: **4.1.8**

REV. 0.00

BY: JB/MA

DATE: 2/7/25

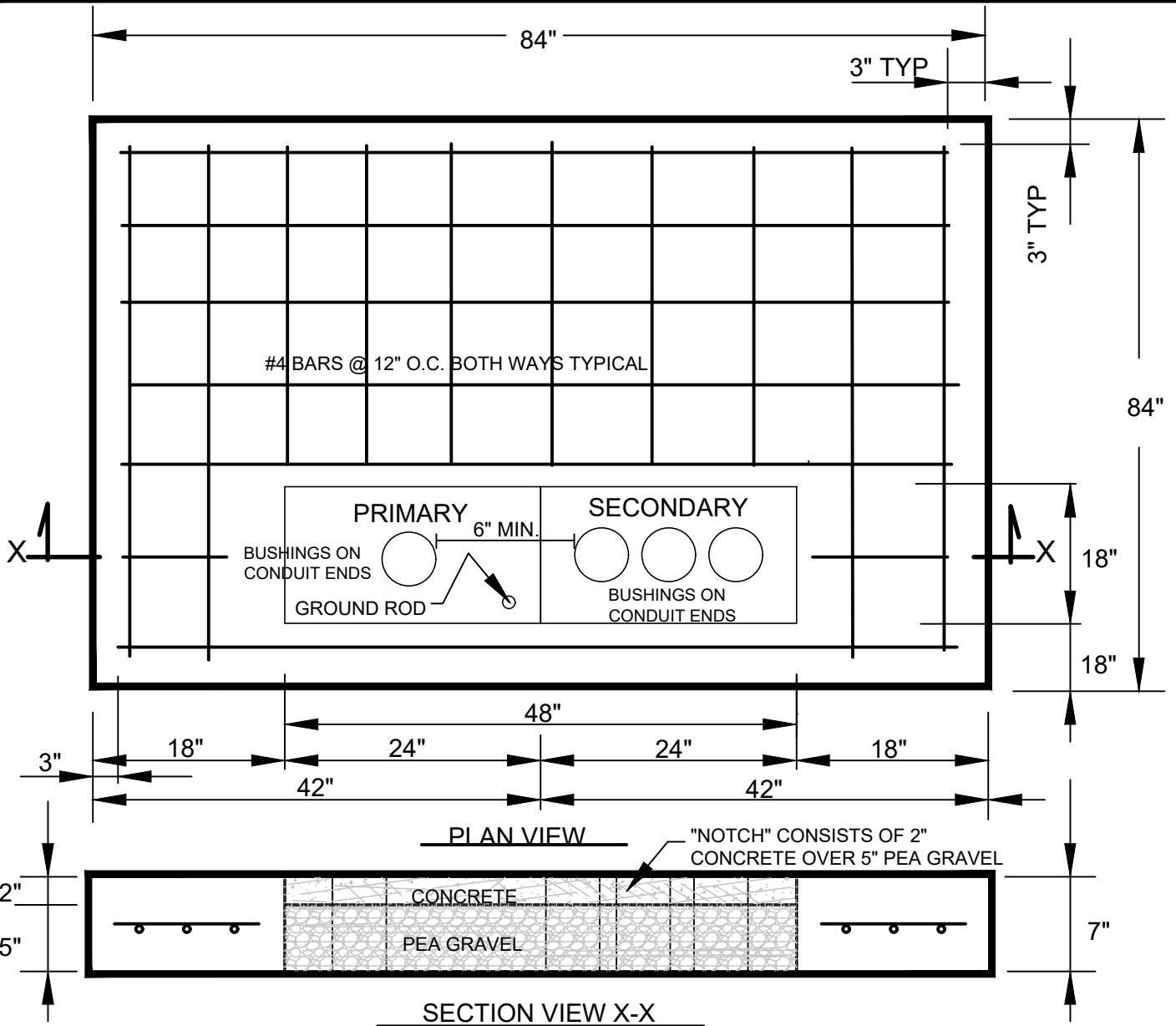

NOTES:

1. PROVIDE #4 BARS @ 12" O.C. BOTH WAYS IN 3,000 PSI CONCRETE ON COMPACTED BASE.
2. INSTALL 5/8 X 8' COPPER CLAD GROUND ROD WITHIN PRIMARY COMPARTMENT.
3. MINIMUM OF 6" SPACE BETWEEN PRIMARY AND SECONDARY CONDUITS.
4. HEBER LIGHT & POWER INSPECTION REQUIRED PRIOR TO CONCRETE PLACEMENT.
5. REQUIRED ACCESS CLEARANCE FOR BOTH SIDES AND REAR OF PAD 3 FT. MIN.
6. REQUIRED ACCESS CLEARANCE IN FRONT OF PAD 10 FT. MINIMUM.
7. CONTRACTOR SHALL PULL AND TERMINATE SECONDARY CONDUCTORS ON ALL 3 PHASE TRANSFORMERS.



REQUIREMENTS & STANDARDS  
**TRANSFORMER PAD  
 3 PHASE  
 UNDERGROUND SERVICE**

DWG: **4.1.9**

REV. 0.00

BY: JB/MA

DATE: 2/7/25

# THREE PHASE TRANSFORMER PAD WITH METERING STATION

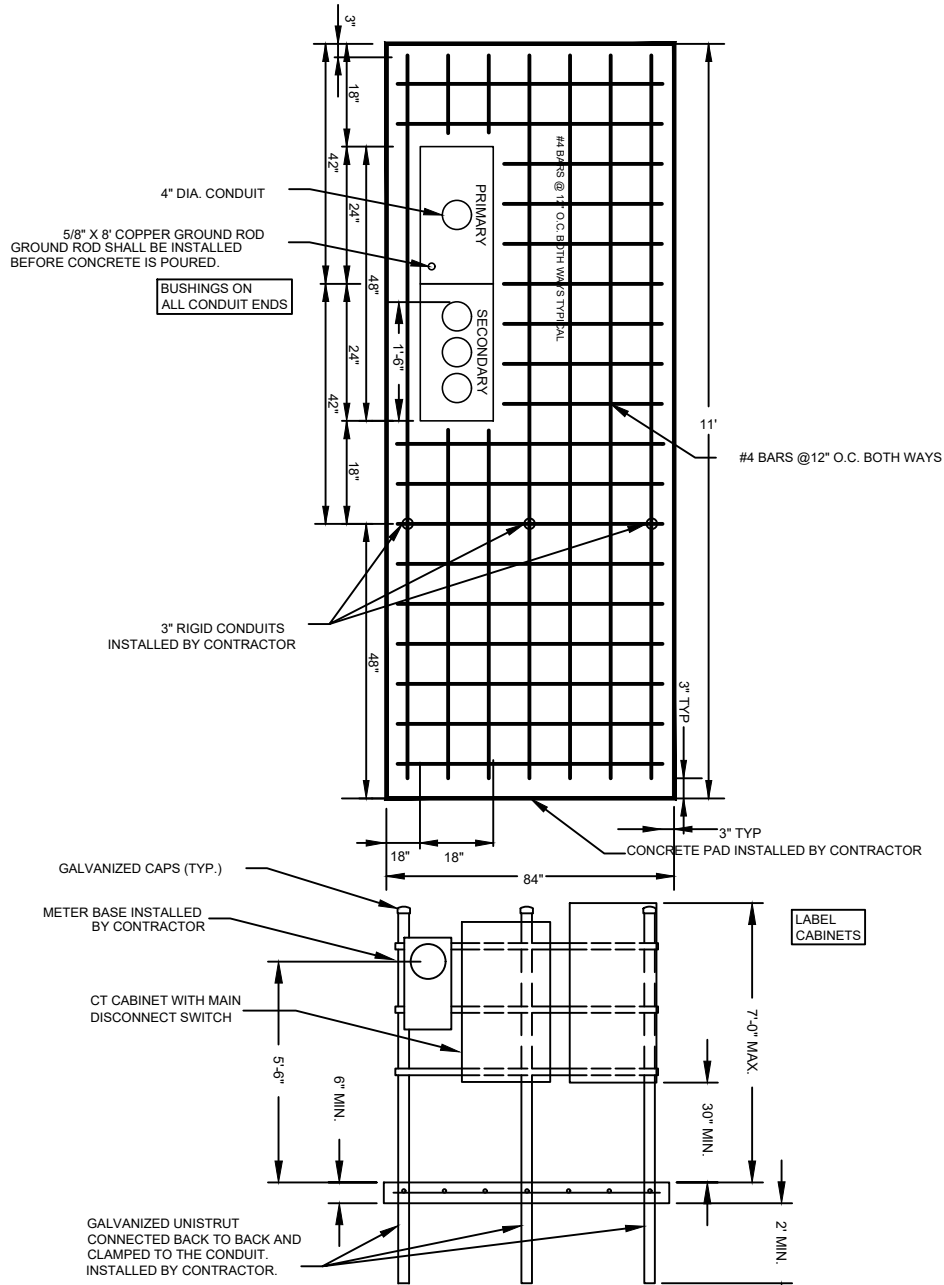

**NOTES:**

1. CONCRETE SHALL BE 3,000 PSI ON COMPACTED BASE. REFER TO 4.1.9 FOR CONCRETE SPECIFICATION.
2. FOLLOW NEC & LOCAL JURISDICTION ON GROUND ROD FOR METER/SERVICE.
3. CONTRACTOR SHALL PULL & TERMINATE CABLES IN ENCLOSURES.
4. CONTRACTOR SHALL PULL AND TERMINATE SECONDARY CONDUCTORS ON ALL 3 PHASE TRANSFORMERS.
5. HEBER LIGHT & POWER INSTALLS CTs & METERING EQUIPMENT. CONTRACTOR DOES THE REST.



## REQUIREMENTS & STANDARDS

# MANUAL 3-PHASE TRANSFORMER PAD

DWG: **4.1.10**

REV. 0.00

BY: JB/MA

DATE: 2/7/25



## TRENCHING REQUIREMENTS

THE DEVELOPER SHALL PROVIDE TRENCHING FOR REQUIRED CONDUIT SYSTEMS AND INSTALL CONDUITS IN ACCORDANCE WITH HEBER LIGHT & POWER STANDARDS.

ALL TRENCHING SHALL CONFORM TO OSHA (CFR 29) REQUIREMENTS. TRENCHES SHALL BE 18" MINIMUM WIDTH, EXCEPT FOR RESIDENTIAL SERVICE TRENCH MAY BE 12" WIDTH. TRENCH DEPTH VARIES BASED ON THE CONDUIT SIZE AND QUANTITY. THE DEVELOPER/CONTRACTOR SHALL BE RESPONSIBLE FOR ALL SHORING AND PROJECT SAFETY COMPLIANCE.

TRENCHING FOR ELECTRICAL POWER CONDUITS SHALL BE LOCATED IN THE FRONT 3' (MINIMUM) OF THE PUBLIC UTILITY EASEMENT (PUE) PROVIDED BY THE OWNER/DEVELOPER. THE PUE IS TYPICALLY 10 FEET FROM THE BACK OF WALK. THE PUE MAY BE 15 FEET IN NON-TYPICAL SITUATIONS (SEE 4.1.8). CONDUITS SHALL BE PLACED, BEDDED AND MARKED WITH APPROVED RED WARNING TAPE AS SHOWN IN THE TRENCHING SECTION/DETAIL 4.2.2. CONDUIT MINIMUM DEPTH IS MEASURED FROM TOP OF CONDUIT TO FINISHED GRADE; 1 FOOT DEPTH PER 1 INCH OF NOMINAL CONDUIT DIAMETER.

ALL BACKFILL MATERIAL SHALL BE COMPACTED. IN AREAS OF THE TRENCH WHERE THERE IS NO EQUIPMENT, PAVING OR OTHER STRUCTURAL REQUIREMENT, THE NATIVE MATERIAL MAY BE USED AS BACK-FILL, PROVIDED IT HAS NO COBBLES, CONSTRUCTION WASTE OR OTHER REFUSE OR DELETERIOUS MATERIALS. EXCAVATED AREAS THAT SUPPORT ELECTRICAL EQUIPMENT, PAVEMENTS, WALKS, ETC. SHALL BE BACKFILLED WITH COMPACTED STRUCTURAL FILL. BACKFILL SHALL BE COMPACTED IN LIFTS NO MORE THAN 2 FEET WITH THE FIRST LIFT BEING VISUALLY INSPECTED, AND THE FINAL COMPACTION SHALL BE 95% OF THE MAXIMUM DRY DENSITY AS DETERMINED BY ASHTO T-99.

ALL CONDUIT SHALL BE BEDDED IN NON-NATIVE MATERIAL- 6" BELOW & 12" ABOVE-SUCH AT MARKER SAND OR  $\frac{1}{4}$ " MINUS PEA GRAVEL.

JOINT TRENCH USE: JOINT USE OF THE TRENCH WITH OTHER UTILITIES IS TYPICALLY NOT ALLOWED. HOWEVER, JOINT USE OF THE POWER TRENCH FOR COMMUNICATIONS IS APPROVED FOR AREAS OF NEW CONSTRUCTION IF 1' HORIZONTAL CLEARANCE CAN BE ACHIEVED. A SEPARATE TRENCH IS REQUIRED FOR NON-ELECTRIC UTILITIES SUCH AS GAS (3' MIN.), SEWER (1' MIN.), AND WATER (1' MIN.).

UTAH LAW SECTION 54-8A-1 THROUGH 54-8A-11 REQUIRES THAT BLUE STAKES ONE-CALL LOCATION CENTER BE NOTIFIED AT LEAST THREE (3) WORKING DAYS PRIOR TO EXCAVATION.

## CONDUIT REQUIREMENTS

TRENCHING AND POWER CONDUIT PLACEMENT SHALL BE DONE AFTER THE CURB AND SIDEWALK IS IN PLACE TO ASSURE PROPER ALIGNMENT IN THE PUE AND VERTICAL LOCATION OF EQUIPMENT. CONDUIT MUST BE PLACED AFTER CURB AND SIDEWALK. THE DEVELOPER IS RESPONSIBLE FOR CORRECT PLACEMENT. ANY CONDUIT WITH INADEQUATE COVER, OR EQUIPMENT MISPLACED IN ELEVATION OR ALIGNMENT SHALL BE REPLACED AT THE DEVELOPERS EXPENSE.

ALL CONDUIT SHALL BE SCHEDULE 40 PVC GRAY FOR ELECTRICAL USE. ELBOW (90 DEGREE) FITTINGS AND OTHER DIRECTIONAL CHANGE FITTINGS (45 OR 22.5 DEGREE) FOR CONDUITS 4" AND 6" DIAMETER SHALL BE PVC AND SHALL HAVE A LONG SWEEP RADIUS OF 36 INCHES. VERTICAL ELBOWS 4"-6" SHALL HAVE  $\frac{1}{2}$  YARD FLOWABLE FILL THRUST BLOCK ON THE INSIDE OF THE RADIUS NOT TO OBSTRUCT JOINTS SO AS TO IMPROVE RESISTANCE TO FORCES GENERATED WHEN PULLING ELECTRICAL CABLES. SEE 4.2.3

FOR CONDUITS 3" DIAMETER, PVC SCHEDULE 40 FITTINGS ARE ACCEPTABLE. ALL BENDS MUST BE LONG SWEEP--WITH MINIMUM RADIUS OF 36 INCHES FOR 3". ALL RMC CONDUITS (SERVICE RISERS, PRIMARY RISERS) SHALL BE TERMINATED WITH PVC BUSHINGS.

CONDUIT SHALL BE PLACED STRAIGHT AND TRUE. CONTRACTOR SHALL KEEP THE INTERIOR OF THE CONDUIT CLEAN AND FREE OF DIRT ROCKS AND DEBRIS. PLUGGED, BROKEN, OR OTHERWISE UNSUITABLE CONDUITS SHALL BE REPLACED AT THE DEVELOPERS EXPENSE. CONDUIT ENDS SHALL BE CAPPED OR TAPED. CONDUIT STUBBED SHALL BE CAPPED AND SUITABLY MARKED AT THE GROUND SURFACE.

MULE TAPE MUST BE INSTALLED WITH ALL POWER CONDUIT. POWER WILL NOT BE INSTALLED UNTIL ALL CRITERIA ARE MET.

DIRECTIONAL BORING MAY BE USED AT SUITABLE LOCATIONS WHERE EXCAVATION IS NOT POSSIBLE, PROBLEMATIC, OR ECONOMICALLY INFEASIBLE. ALL SIZES BORING CONDUIT SHALL BE "STRAIGHT STICK" WELDED SEAM WITH THE INSIDE SEAM REAMED TO PROVIDE A SMOOTH AND CONSISTENT INSIDE DIAMETER. ALL HDPE SHALL BE BEVELED INSIDE PIPE AT A 45 DEGREE ANGLE AT ALL FITTINGS, CONNECTIONS, AND WHERE BORE BORE PIPE AND PVC MEET. HDPE ID SHALL MATCH AS CLOSE AS POSSIBLE TO PVC ID. CONTACT HEBER LIGHT & POWER FOR APPROVAL OF PROPOSED SOLUTION.

THE CONTRACTOR SHALL PERFORM MANDREL TESTING ON HDPE BORED CONDUIT WITH THE HEBER LIGHT & POWER INSPECTOR ON SITE. SEE DRAWING 4.2.4



## REQUIREMENTS & STANDARDS ELECTRICAL TRENCH & CONDUIT NOTES

RESIDENTIAL & COMMERCIAL POWER SERVICE

DWG: **4.2.1**

REV. 0.00

BY: JB/MA

DATE: 1/20/25

FINAL GRADE

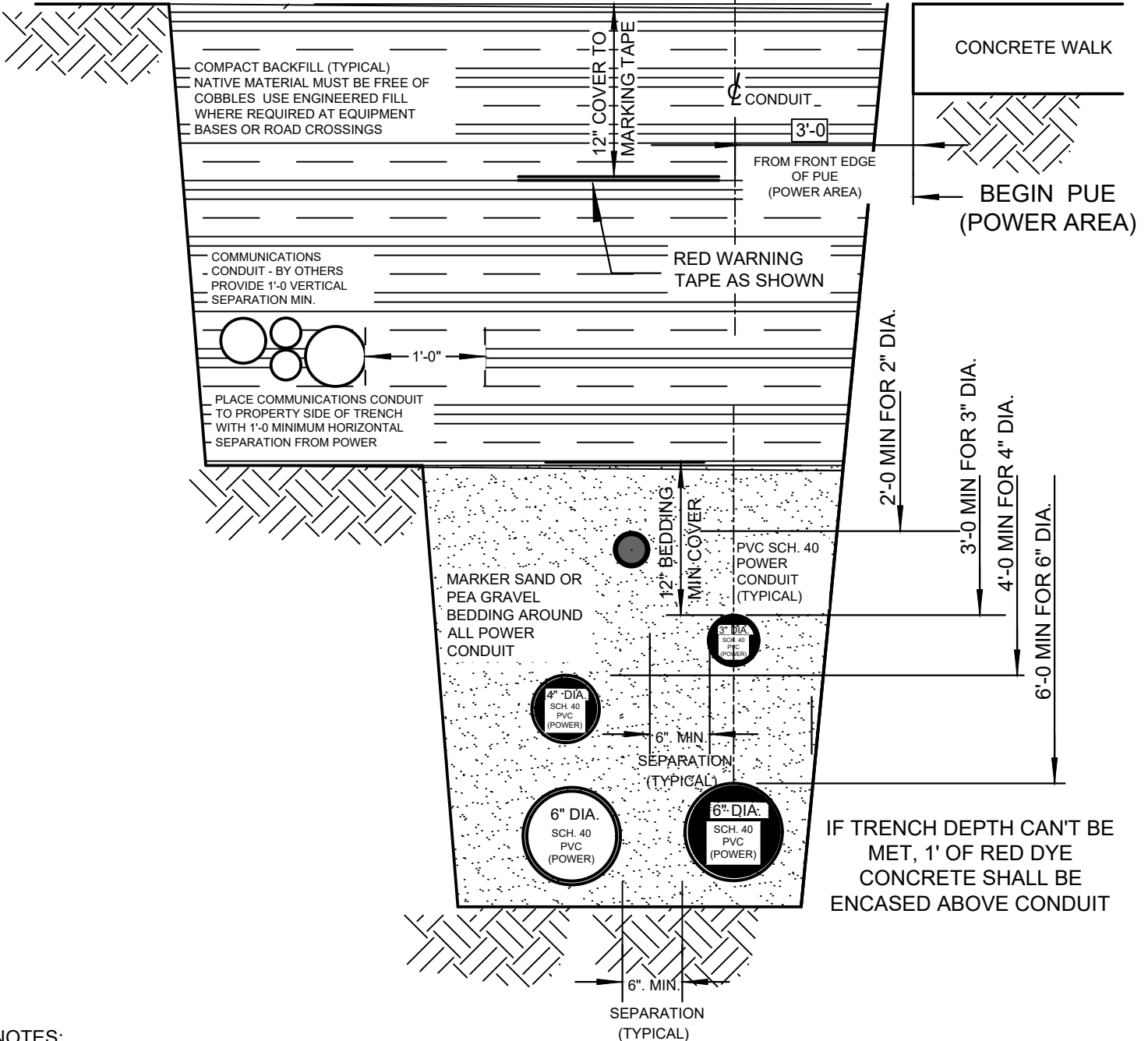

**NOTES:**

1. BEDDING & BACKFILL MATERIAL MUST BE APPROVED BY HEBER LIGHT & POWER
2. INSPECTION REQUIRED PRIOR TO BACKFILL COMPACTION TESTING REQUIRED. REFER TO 4.2.1
3. SERVICE LATERAL DEPTH 36" MINIMUM.
4. PROVIDE BEDDING ON ALL CONDUIT SURFACES AND 6" SEPARATION BETWEEN POWER CONDUITS
5. PROVIDE DEPTH OF 1 FOOT TO TOP OF CONDUIT FOR EVERY 1 INCH OF NOMINAL DIAMETER
6. PVC CONDUIT SHALL NOT BE HEATED TO MAKE BENDS. ONLY CONDUIT WITH FACTORY BENDS WILL BE ACCEPTED.



**REQUIREMENTS & STANDARDS**  
**POWER TRENCH &  
 JOINT USE TRENCH DETAIL**  
**RESIDENTIAL & COMMERCIAL SUBDIVISION**

DWG: **4.2.2**

REV. 0.00

BY: JB/MA

DATE: 1/20/25

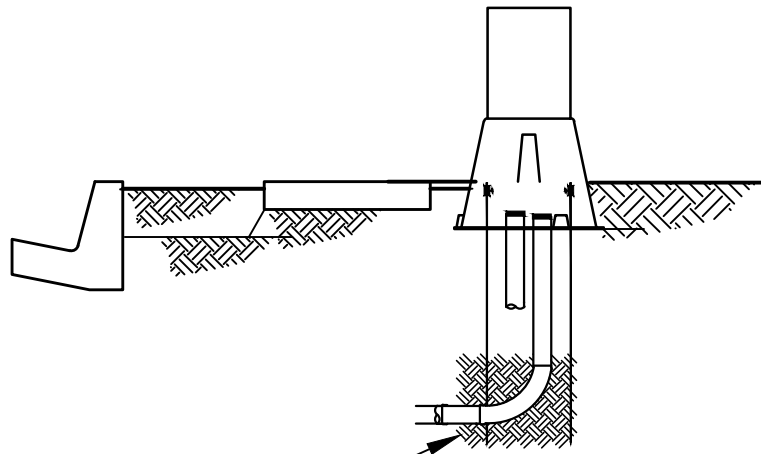

( SECTION VIEW )

4" OR 6"  
PVC CONDUIT  
VERTICAL 90°  
ELBOW LONG SWEEP

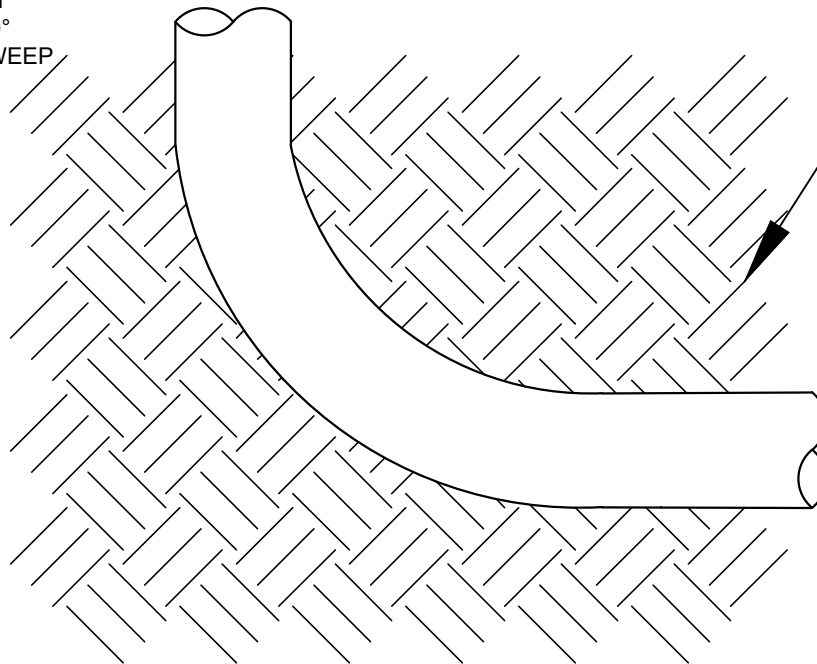

1/2 YARD FLOWABLE  
FILL ON  
INSIDE RADIUS

NOTES:

1. SEE REQUIREMENTS IN 4.2.1.



REQUIREMENTS & STANDARDS  
**POWER TRENCH & CONDUIT  
THRUST BLOCK (EXAMPLE)**

RESIDENTIAL & COMMERCIAL SUBDIVISION

DWG: **4.2.3**

REV. 0.00

BY: JB/MA

DATE: 11/12/24

MANDREL REQUIRED ON ALL CONDUIT-PVC, RMC, AND HDPE

MANDREL TABLE	
CONDUIT (NOM.) DIAMETER	MANDREL DIAMETER
3"	2.7"
4"	3.6"
6"	5.4"

\* ALL HDPE SHALL BE BEVELED WHERE BORE PIPE AND PVC MEET.



REQUIREMENTS & STANDARDS

MANDREL TABLE

RESIDENTIAL & COMMERCIAL POWER SERVICE

DWG: **4.2.4**

REV. 0.00

BY: JB/MA

DATE: 1/20/25

# EQUIPMENT EROSION PREVENTION

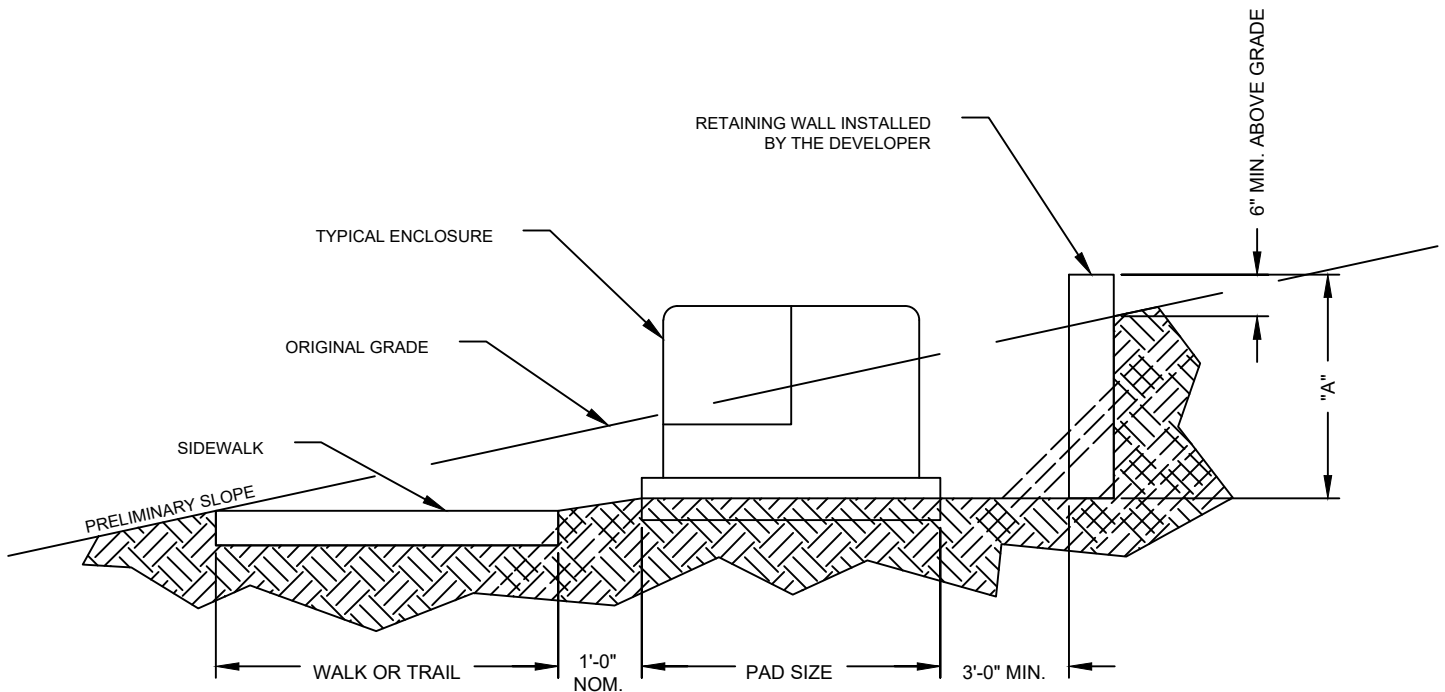

**NOTES:**

1. WHEN IT BECOMES NECESSARY TO NOTCH-OUT OR FILL A SLOPE TO INSTALL AN ENCLOSURE OR TRANSFORMER, THE CLEARED AREA SHOULD BE SUFFICIENT SIZE TO ACCOMMODATE THE ENCLOSURE AND SHORINGS. THE FRONT OF THE PAD SHALL BE PLACED 2" (MAX.) ABOVE THE SIDEWALK.
2. AREA UNDER AND BEHIND PAD MUST BE LEVELED AND COMPACTED AS PER TRENCH SPECIFICATIONS 4.2.1.
3. A RETAINING STRUCTURE IS REQUIRED IF DIMENSION "A" IS GREATER THAN 12". THE STRUCTURE MUST BE OUTSIDE OF THE EASEMENT
4. SIDE RETAINING WALLS ARE ALSO REQUIRED IF DIMENSION "A" IS GREATER THAN 18". RETAINING WALL SHALL BE 6" ABOVE EXISTING GRADE AND 18" FROM EACH SIDE AND BEHIND ENCLOSURE.
5. ALL GRADING SHALL BE PERFORMED BY DEVELOPER.
6. CONTACT HEBER LIGHT & POWER IF ASSISTANCE IS REQUIRED.



REQUIREMENTS & STANDARDS  
**POWER EQUIPMENT  
 EROSION PREVENTION**

RESIDENTIAL & COMMERCIAL POWER SERVICE

DWG: **4.2.5**

REV. 0.00

BY: JB/MA

DATE: 1/20/25

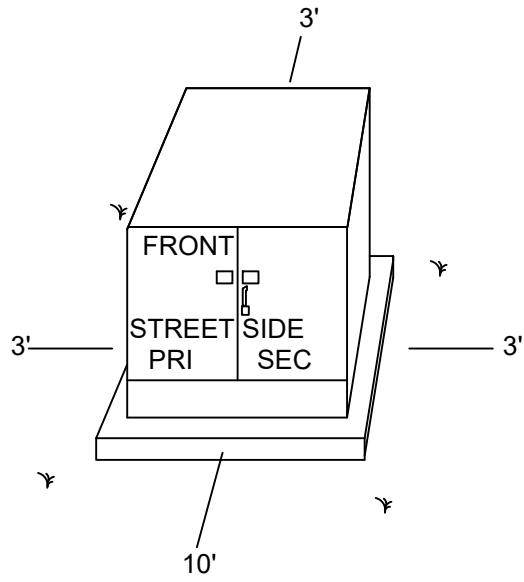
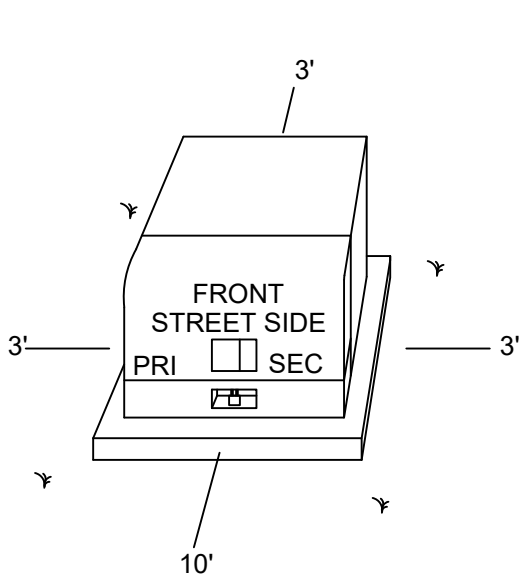

**RESIDENTIAL SINGLE-PHASE TRANSFORMER**

**COMMERCIAL 3-PHASE TRANSFORMER**

**PADMOUNTED EQUIPMENT**

**PADMOUNTED EQUIPMENT**

NOTE:

IN THE EVENT OF AN EQUIPMENT FAILURE OR POWER OUTAGE, IT IS NECESSARY FOR UTILITY CREWS TO HAVE ADEQUATE ACCESS TO PADMOUNTED EQUIPMENT AND TRANSFORMERS. ACCESS TO THE FRONT SHALL BE TEN (10) FEET, ACCESS TO THE REAR AND SIDES SHALL BE THREE (3) FEET MINIMUM. NO TREES, SHRUBS, FENCES, LARGE LANDSCAPE ROCKS, OR OTHER OBSTRUCTIONS SHALL BE PERMITTED IN ACCESS AREA. PLACEMENT SHALL BE AS INDICATED ON STAKING SHEETS.

NOTE FOR NEW SERVICES

1. PADMOUNTED EQUIPMENT, TRANSFORMERS AND SECONDARY JUNCTION BOXES ARE LOCKED FOR PROTECTION AGAINST ELECTRICAL SHOCK.
2. WHEN INSTALLATION OF A NEW SERVICE REQUIRES ACCESS TO A TRANSFORMER OR SECONDARY JUNCTION BOX, OWNER/CONTRACTOR SHALL CONTACT HEBER LIGHT & POWER.
3. ALL NEW CONDUIT RUNS SHALL BE INSTALLED BY CONTRACTOR INTO TRANSFORMER/SECONDARY JUNCTION BOX WITH HEBER LIGHT & POWER SUPERVISION. SEE STANDARDS DETAILS IN 4.1.0 TO 4.1.9 AND 4.2.1 FOR REQUIREMENTS.
4. BLUE STAKE LAWS PROHIBIT ANY DIGGING NEAR EQUIPMENT WITHIN THE 2' SAFETY ZONE. PLEASE HAND DIG AROUND ANY ELECTRICAL EQUIPMENT.
5. REFER TO 5.4 FOR CLEARANCE TO COMBUSTIBLE STRUCTURES FROM TRANSFORMERS.
6. FOR RESIDENTIAL SERVICES: INITIAL WIRE PULL WILL BE HEBER LIGHT & POWER'S. AFTER INTIAL INSTALLATION CUSTOMER WILL BE RESPONSIBLE FOR ALL COSTS TO MAINTAIN/REPLACE CONDUIT AND CONDUCTOR FROM POWER SOURCE TO METER.
7. FOR COMMERCIAL SERVICES: OWNER/CONTRACTOR IS REQUIRED TO SUPPLY AND PULL SECONDARY CONDUIT AND CONDUCTOR. AFTER INITIAL INSTALLATION CUSTOMER WILL BE RESPONSIBLE FOR ALL COSTS TO MAINTAIN/REPLACE CONDUIT AND CONDUCTOR FROM POWER SOURCE TO METER.



**REQUIREMENTS & STANDARDS**

**TRANSFORMER & EQUIPMENT  
REQUIRED CLEARANCES**

**RESIDENTIAL & COMMERCIAL POWER SERVICE**

DWG: <b>5.1</b>
REV. 0.00
BY: JB/MA
DATE: 2/7/25



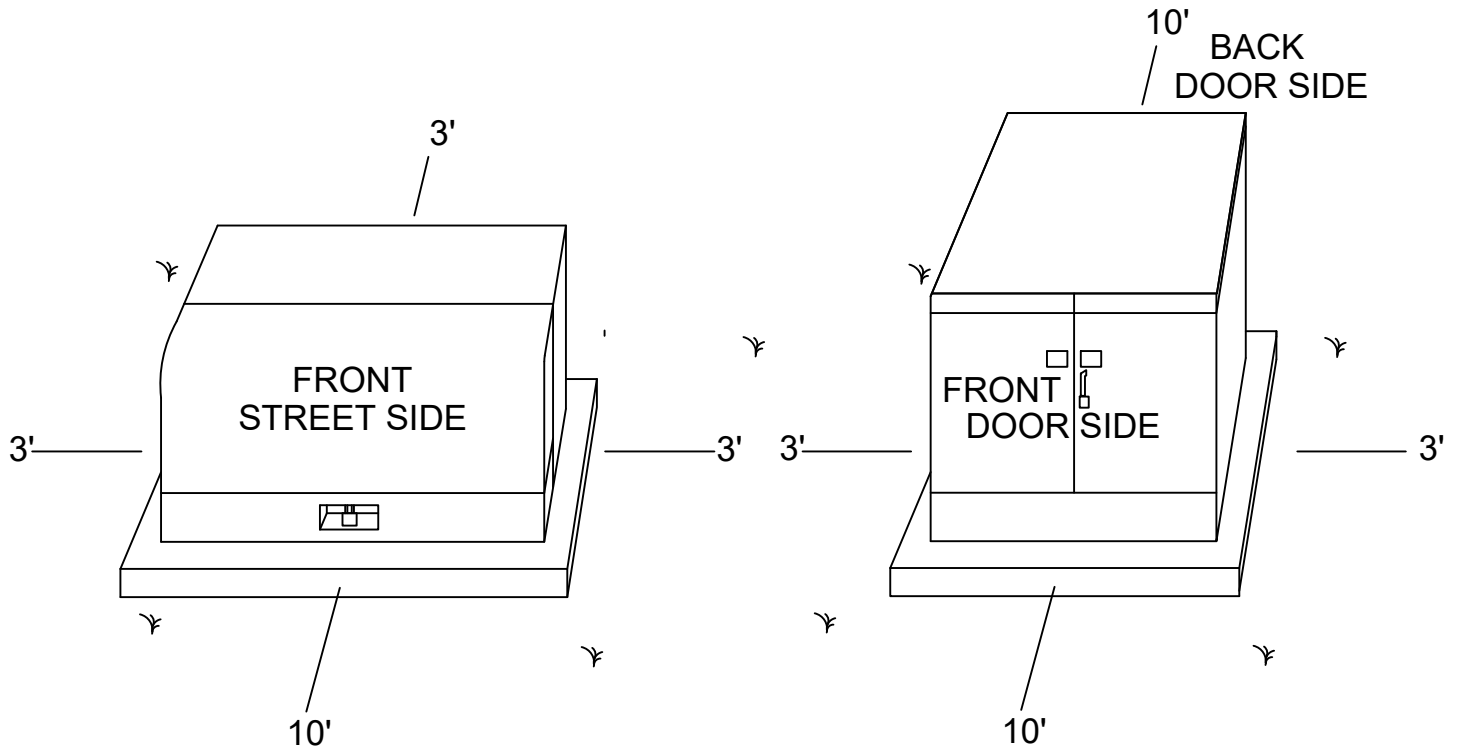

**PRIMARY SECTIONALIZER**  
**PADMOUNTED EQUIPMENT**

**PRIMARY SWITCHGEAR**  
**PADMOUNTED EQUIPMENT**

**NOTE:**

IN THE EVENT OF AN EQUIPMENT FAILURE OR POWER OUTAGE, IT IS NECESSARY FOR UTILITY CREWS TO HAVE ADEQUATE ACCESS TO PADMOUNTED EQUIPMENT AND TRANSFORMERS. ACCESS TO THE FRONT SHALL BE TEN (10) FEET, ACCESS TO BOTH DOOR SIDES OF A SWITCHGEAR SHALL BE TEN (10) FEET, ACCESS TO THE REAR OF SECTIONALIZERS AND SIDES SHALL BE THREE (3) FEET MINIMUM. NO TREES, SHRUBS, FENCES, LARGE LANDSCAPE ROCKS, OR OTHER OBSTRUCTIONS SHALL BE PERMITTED IN ACCESS AREA. PLACEMENT SHALL BE AS INDICATED ON STAKING SHEETS.

**NOTE FOR NEW SERVICES**

1. PADMOUNTED EQUIPMENT, TRANSFORMERS AND SECONDARY JUNCTION BOXES ARE LOCKED FOR PROTECTION AGAINST ELECTRICAL SHOCK.
2. WHEN INSTALLATION OF A NEW SERVICE REQUIRES ACCESS TO A TRANSFORMER OR SECONDARY JUNCTION BOX, OWNER/CONTRACTOR SHALL CONTACT HEBER LIGHT & POWER.
3. ALL NEW CONDUIT RUNS SHALL BE INSTALLED BY CONTRACTOR INTO TRANSFORMER/SECONDARY JUNCTION BOX WITH HEBER LIGHT & POWER SUPERVISION. SEE STANDARD DETAILS IN 4.1.0 TO 4.1.9 AND 4.2.1 FOR REQUIREMENTS.
4. BLUE STAKE LAWS PROHIBIT ANY DIGGING NEAR EQUIPMENT WITHIN THE 2' SAFETY ZONE. PLEASE HAND DIG AROUND ANY ELECTRICAL EQUIPMENT.
5. REFER TO 5.4 FOR CLEARANCE TO COMBUSTIBLE STRUCTURES FROM TRANSFORMERS.



**REQUIREMENTS & STANDARDS**

**TRANSFORMER & EQUIPMENT  
REQUIRED CLEARANCES**

**RESIDENTIAL & COMMERCIAL POWER SERVICE**

DWG: **5.2**

REV. 0.00

BY: JB/MA

DATE: 2/7/25

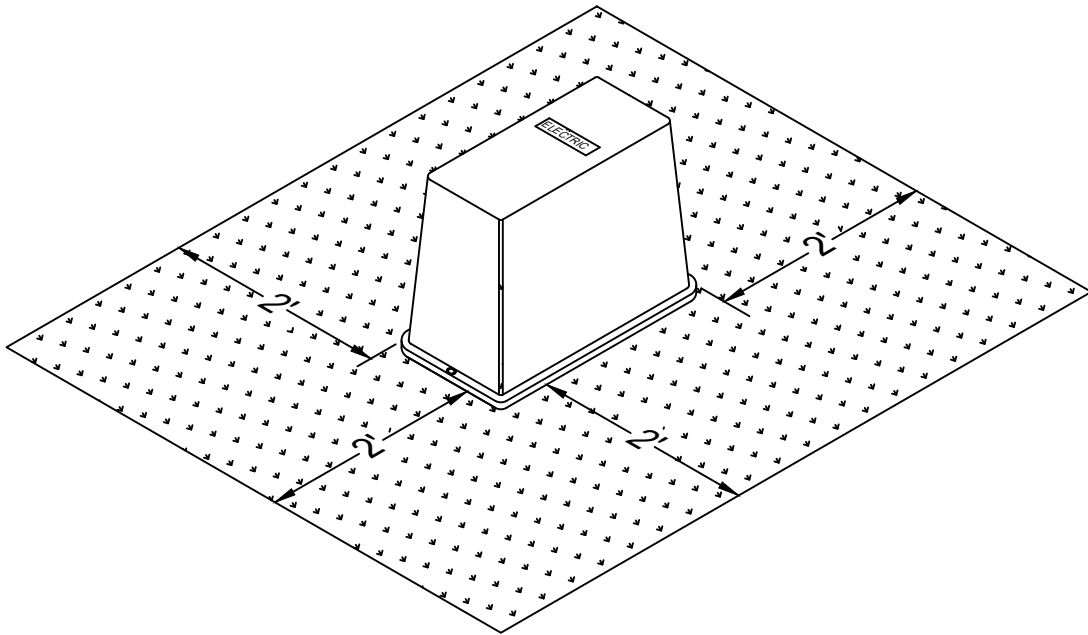

**SECONDARY JUNCTION BOXES**  
(TYP. 15" x 15" LID APPROX.)

**NOTE:**  
IN THE EVENT OF AN EQUIPMENT FAILURE OR POWER OUTAGE, IT IS NECESSARY FOR HEBER LIGHT & POWER CREWS TO HAVE ADEQUATE ACCESS TO SECONDARY JUNCTION BOXES. ACCESS TO THE FRONT AND SIDES AND REAR SHALL BE 2 FEET MINIMUM. NO TREES, SHRUBS, FENCES, LARGE LANDSCAPE ROCKS, OR OTHER OBSTRUCTIONS SHALL BE PERMITTED IN ACCESS AREA. PLACEMENT SHALL BE AS INDICATED ON STAKING SHEETS.

DEVELOPER/CONTRACTOR SHALL BE CHARGED FOR ALL BROKEN/DAMAGED EQUIPMENT UP TO THE TIME THE HOMEOWNER TAKES OCCUPANCY.

NOTE FOR NEW SERVICES

1. NEW SECONDARY JUNCTION BOXES SHALL BE THOSE SPECIFIED BY HEBER LIGHT & POWER. ANY "OR EQUAL" SUBSTITUTIONS MUST BE APPROVED IN WRITING BY HEBER LIGHT & POWER.
2. TRANSFORMERS AND SECONDARY JUNCTION BOXES ARE LOCKED FOR PROTECTION AGAINST ELECTRICAL SHOCK.
3. WHEN INSTALLATION OF A NEW SERVICE REQUIRES ACCESS TO A TRANSFORMER OR SECONDARY JUNCTION BOX, OWNER\CONTRACTOR SHALL NOTIFY HEBER LIGHT & POWER.
4. ALL NEW CONDUIT RUNS SHALL BE INSTALLED BY CONTRACTOR INTO TRANSFORMER \SECONDARY JUNCTION BOX WITH HEBER LIGHT & POWER SUPERVISION. SEE 4.1.0 FOR REQUIREMENTS.
5. BLUE STAKE LAWS PROHIBIT ANY DIGGING WITH EQUIPMENT WITHIN THE 2' SAFETY ZONE. PLEASE HAND DIG AROUND ANY ELECTRICAL EQUIPMENT.



**REQUIREMENTS & STANDARDS**  
**CLEARANCE REQUIRED**  
**FOR**  
**SECONDARY JUNCTION BOX**  
**RESIDENTIAL & COMMERCIAL POWER SERVICE**

DWG: **5.3**

REV. 0.00

BY: JB/MA

DATE: 2/7/25

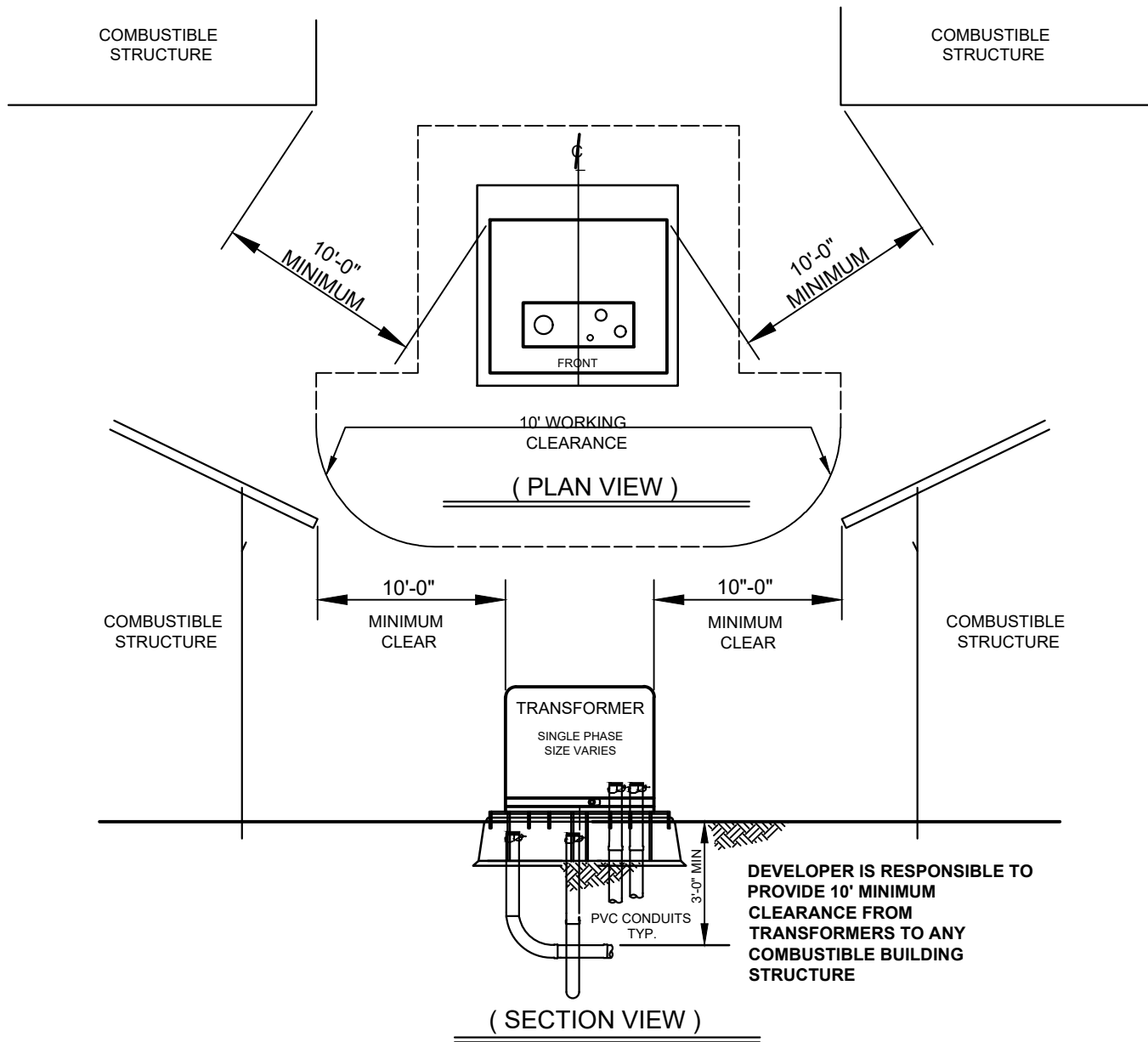

DEVELOPER IS RESPONSIBLE TO PROVIDE 10' MINIMUM CLEARANCE FROM TRANSFORMERS TO ANY COMBUSTIBLE BUILDING STRUCTURE

**NOTES:**

1. CLEARANCE REQUIRED ACCORDING TO NEC 450.27.
2. ADDITIONAL CLEARANCES MAY BE REQUIRED BY APPLICABLE LOCAL AND STATE BUILDING CODES.



**REQUIREMENTS & STANDARDS**  
**CLEARANCE TO**  
**COMBUSTIBLE STRUCTURES**  
**FROM TRANSFORMERS**  
**(LOCATED IN THE P.U.E.)**

DWG: <b>5.4</b>
REV. 0.00
BY: JB/MA
DATE: 2/7/25

**SERVICE DROP CONDUCTORS SHALL NOT BE READILY ACCESSIBLE.**

**NOTES:**

1. IF A ROOF OR BALCONY IS NOT READILY ACCESSIBLE TO PEDESTRIANS AND THE SERVICE CABLE IS MULTIPLEX (UP TO 600 VOLTS) OR IS INSULATED OPEN WIRE (UP TO 300 VOLTS BETWEEN CONDUCTORS, I.E. NOT INCLUDING 480 VOLT WYE OR DELTA), THE CLEARANCE MAY BE A MINIMUM OF 3 FEET PER NESC 234C3d(1) EXCEPTION 2. (NEC 230-24 ALSO REQUIRES 3' MINIMUM FOR UP TO 300 VOLTS BETWEEN CONDUCTORS AND A ROOF SLOPE OF AT LEAST 4" IN 12" TO BE CONSIDERED NOT ACCESSIBLE TO PEDESTRIANS.) NESC DEFINES A ROOF OR BALCONY READILY ACCESSIBLE TO PEDESTRIANS IF IT CAN BE CASUALLY ACCESSED THROUGH A DOORWAY, WINDOW, RAMP, STAIRWAY, OR PERMANENT LADDER (WITH ITS BOTTOM RUNG LESS THAN 8' FROM GROUND OR FROM PERMANENT ACCESSIBLE SURFACE) BY A PERSON, ON FOOT, WHO NEITHER EXERTS EXTRAORDINARY PHYSICAL EFFORT NOR EMPLOYS SPECIAL TOOLS OR DEVICES TO GAIN ENTRY. NESC SHALL GOVERN FROM THE UTILITY'S POLE TO THE DRIP LOOP AT THE CUSTOMER'S SERVICE ENTRANCE; NEC SHALL GOVERN FROM THAT DRIP LOOP INTO THE BUILDING.
2. WHERE NOT MORE THAN 6 FEET (MEASURED HORIZONTALLY) OF A SERVICE DROP PASSES OVER A ROOF TO TERMINATE AT A (THROUGH-THE-ROOF) SERVICE RACEWAY OR APPROVED SUPPORT LOCATED NOT MORE THAN 4' MEASURED HORIZONTALLY FROM THE NEAREST EDGE OF ROOF AND THE CABLE IS EITHER MULTIPLEX (UP TO 600 VOLTS), OR IS INSULATED OPEN WIRE (UP TO 300 VOLTS BETWEEN CONDUCTORS, I.E. NOT INCLUDING 480 VOLT WYE OR DELTA), THE CLEARANCE ABOVE THE ROOF MAY BE A MINIMUM OF 18". SEE THE PLAN VIEW SKETCH BELOW. (NEC 230-24 ALLOWS THE SAME 18" CLEARANCE FOR SERVICES UP TO 300 VOLTS BETWEEN CONDUCTORS AND SIMILAR OVERHANG.)

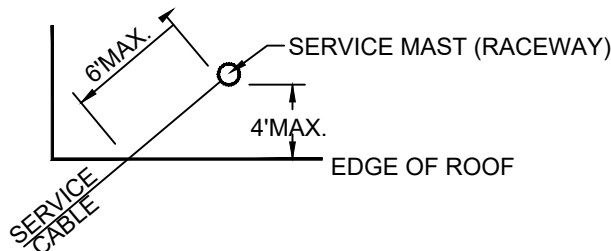

3. A CLEARANCE OF 3 FEET IN ANY DIRECTION FROM WINDOWS, DOORS, FIRE ESCAPES, OR SIMILAR LOCATIONS IS REQUIRED, EXCEPT IT DOES NOT APPLY TO:
  - A. MULTIPLEX CABLE ABOVE THE TOP OF A WINDOW, OR
  - B. WINDOWS THAT DO NOT OPEN.(NEC 230-9 REQUIRES THE SAME 3' OF CLEARANCE EXCEPT ABOVE THE TOP LEVEL OF A WINDOW; SERVICE CONDUCTORS ARE NOT ALLOWED BELOW WINDOWS OR OPENINGS THROUGH WHICH MATERIALS MAY BE MOVED, E.G. IN FARM OR COMMERCIAL BUILDINGS.)
4. PER NESC RULE 235C1 (EXCEPTION 3) A SPACE OF NOT LESS THAN 12" IS REQUIRED BETWEEN ELECTRIC SERVICE DROPS OF 0-600 VOLTS RUNNING ABOVE AND PARALLEL TO COMMUNICATION SERVICE DROPS. THIS APPLIES TO ANY POINT IN THE SPAN AS WELL AS AT THE BUILDING ATTACHMENT. OTHER CLEARANCES APPLY AT THE POLE. IF THESE SERVICES ARE RUN FROM DIFFERENT SUPPORT STRUCTURES, NESC TABLE 233-1 REQUIRES 24" VERTICAL CLEARANCE BETWEEN CONDUCTORS. COMMUNICATION CABLES SHOULD BE INSTALLED BELOW POWER SUPPLY CONDUCTORS WHENEVER POSSIBLE.

**CAUTION:**

**ALL NESC VERTICAL CLEARANCES APPLY TO THE CONDUCTORS AT MAXIMUM FINAL SAG. ALLOW FOR 1.0 FOOT OF ADDITIONAL SAG FOR INCREASE FROM INITIAL SAG TO MAXIMUM FINAL CONDITIONS.**



**REQUIREMENTS & STANDARDS  
CLEARANCES FOR  
SERVICE DROPS <600 VOLT  
FOR BUILDINGS, SIGNS & OTHER  
INSTALLATIONS**

**RESIDENTIAL & COMMERCIAL POWER SERVICE**

DWG: **5.5**

REV. 0.00

BY: JB/MA

DATE: 2/7/25

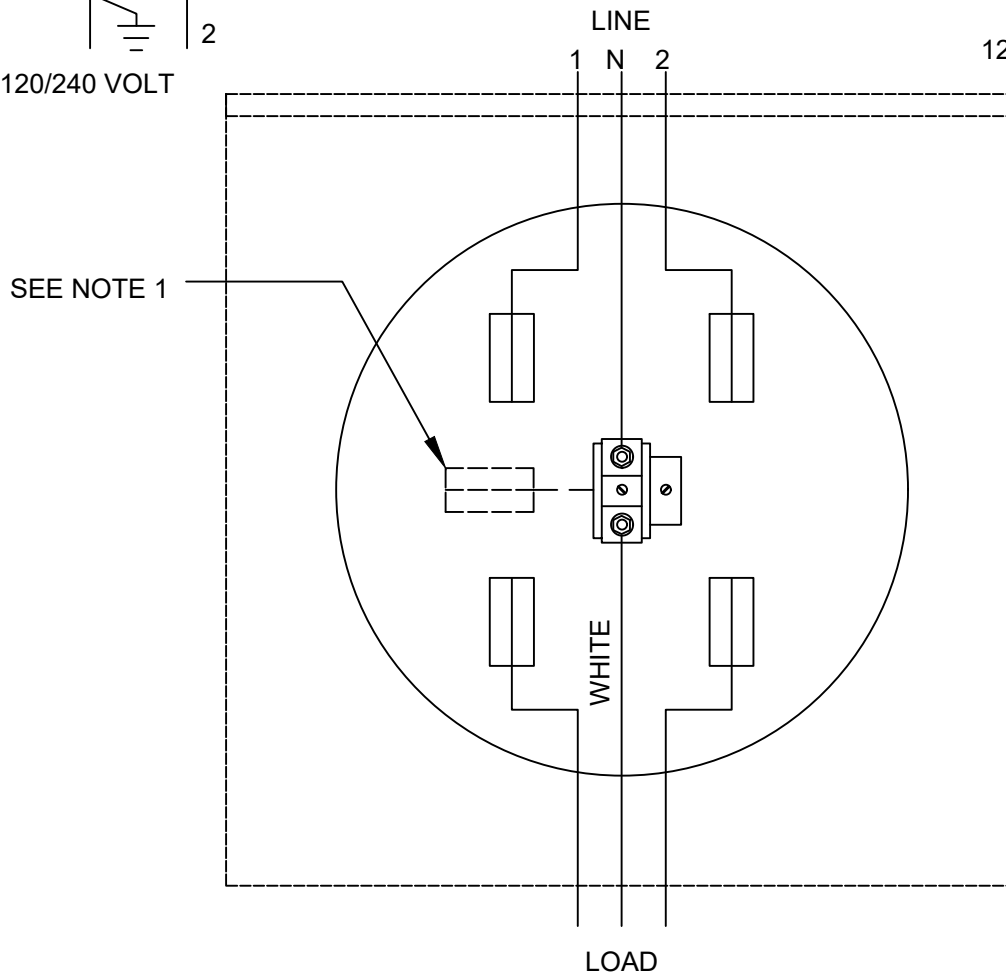
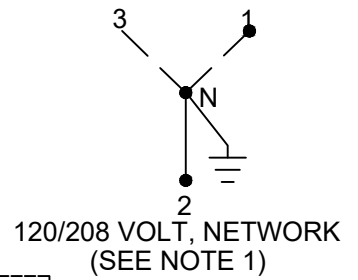
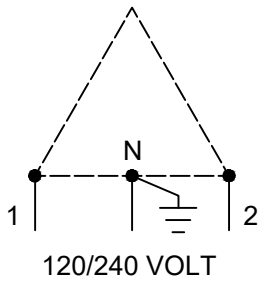

**NOTES:**

1. A FIFTH TERMINAL (STINGER) IS REQUIRED FOR A 120/208V SERVICE.
2. WIRE SIZE RANGE:
  - 2.1 - 100 AMP SOCKET: LUGS SUITABLE FOR #6 - #2/0 STRANDED CU/AL CONDUCTORS.
  - 2.2 - 200 AMP SOCKET: LUGS SUITABLE FOR #2 - 350 KCMIL CU/AL CONDUCTORS.
3. APPROXIMATE DIMENSIONS:
  - 3.1 - 100 AMP SOCKET: 3-5/16"(D) X 8"(W) X 11-1/2"(H).
  - 3.2 - 200 AMP SOCKET: 4-3/8"(D) X 11"(W) X 15-1/2"(H).
4. CONTACT HEBER LIGHT & POWER FOR AVAILABLE SERVICE VOLTAGES.



**REQUIREMENTS & STANDARDS**  
**METER SOCKET**  
**SINGLE PHASE WIRING DIAGRAM**  
**120/240 VOLT OR 120/208 VOLT**  
 100 - 200 AMP RESIDENTIAL OR COMMERCIAL

DWG: **6.1.1**

REV. 0.00

BY: JB/MA

DATE: 11/14/24

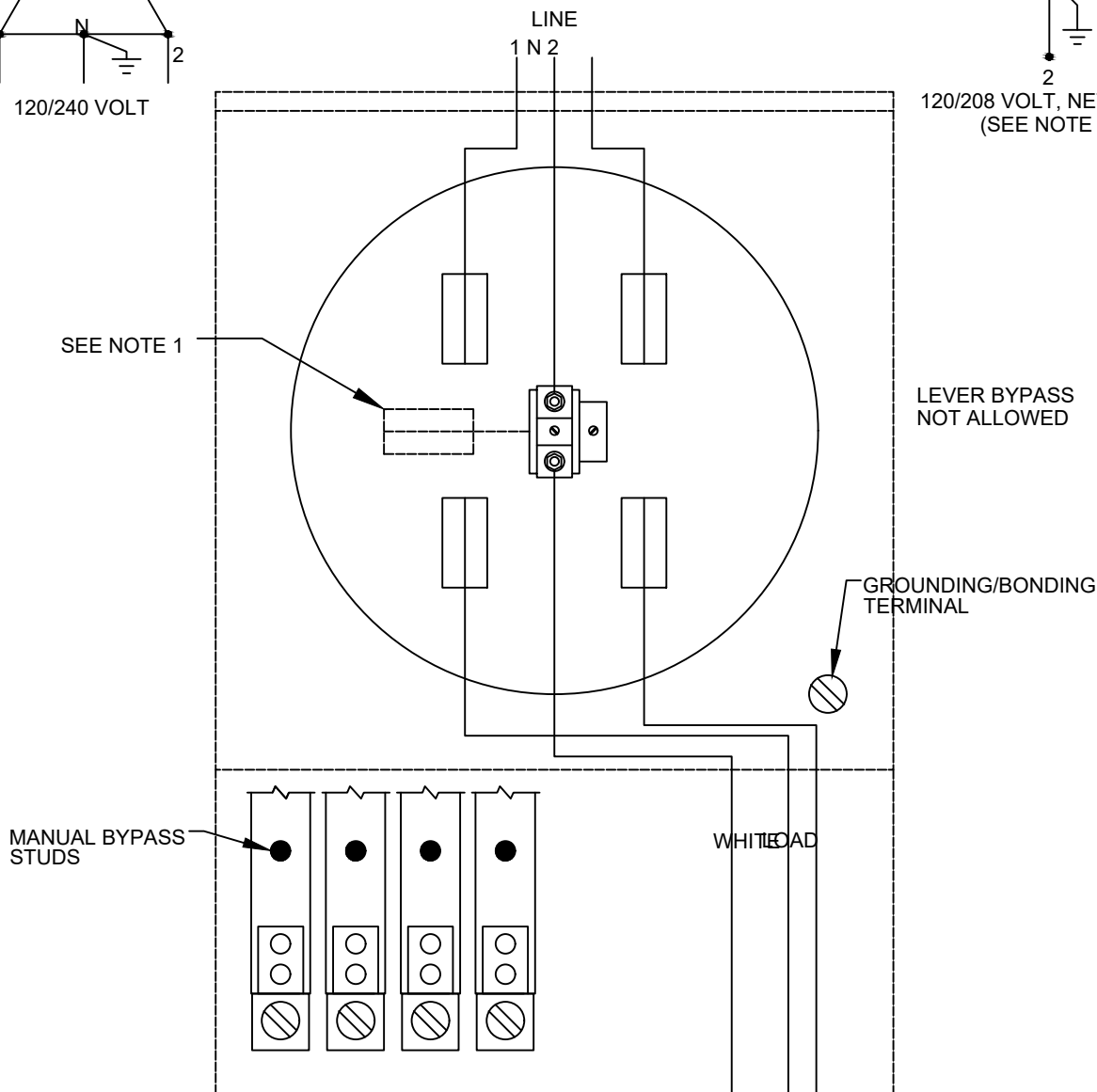
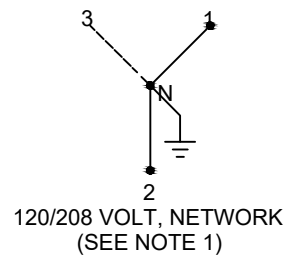
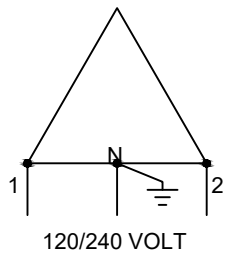

**NOTES:**

1. A FIFTH TERMINAL (STINGER) IS REQUIRED FOR A 120/208V SERVICE.
2. WIRE SIZE RANGE: LUGS SUITABLE FOR #2 - 350 kcmil Cu/Al CONDUCTORS.
3. APPROXIMATE DIMENSIONS: 5"(D) x 13"(W) x 19"(H).
4. METER SOCKET SHALL HAVE BYPASS. (LINK OR MANUAL)
5. KNOCKOUTS: THREE ON BOTTOM AND ONE EACH ON BOTH SIDES AND BACK; KNOCKOUTS ARE CONCENTRIC TYPE WITH A MAXIMUM DIAMETER OF 3".
6. FOR OVERHEAD SERVICES, METER SOCKETS ARE FURNISHED WITH A HUB SIZED AS NEEDED; AVAILABLE HUB SIZES ARE 1-1/4", 1-1/2", 2" AND 2-1/2" .



**REQUIREMENTS & STANDARDS**  
**METER SOCKET UP TO 400 AMP**  
**WIRING DIAGRAM**  
**3 WIRE WYE 1 PHASE**  
**120/240 OR 277/480 VOLT**  
 (5 TERMINAL SOCKET W/ LINK BY-PASS)

DWG: **6.1.2**

REV. 0.00

BY: JB/MA

DATE: 11/14/24

ALL NON-CURRENT CARRYING METALLIC PARTS TO BE BONDED TO NEUTRAL AND EFFECTIVELY GROUNDED -SEE DRAWINGS 6.4.1 AND 6.4.2 FOR TYPICAL GROUNDING AND BONDING DETAILS.

ALL CABIN COMMUNITIES ARE REQUIRED TO INSTALL A FREE-STANDING METER WITHIN 20 FEET OF TRANSFORMER OR SECONDARY BOX.

LABEL EACH METER PLATE WITH UNIT # ENGRAVED METAL OR PLASTIC

INCLUDE GROUNDING BUSHING ABOVE HUB

SPACER (AS NEEDED)

EACH METER HAS ITS OWN DISCONNECT (BREAKER)

STRUCTURE WITH TWO METERS OR MORE SHALL BE BANKED. BANKED METER SERVICES-CONDUCTOR PULLED BY CONTRACTOR.

LOCAL MUNICIPAL BUILDING INSPECTION SHALL INSPECT ELECTRICAL SERVICE PRIOR TO CONNECTION BY HEBER LIGHT & POWER.

HEBER LIGHT & POWER SHALL DETERMINE LOCATION OF ALL METER EQUIPMENT. CONTACT HEBER LIGHT & POWER.

NO METERS WILL BE ALLOWED INSIDE ENCLOSED SPACE WITHOUT WRITTEN APPROVAL FROM HEBER LIGHT & POWER.

ANCHOR RISER TO CONCRETE FOUNDATION WALL. ANCHOR WITH PIPE CLAMP TO 6" MIN UNISTRUT WITH (2) 5/16" DIA. ANCHORS WITH 2-1/2" EMBEDMENT (MIN.)

RMC INSTALLED BELOW GRADE SHALL BE SUITABLY WRAPPED W/ PVC TAPE FOR PROTECTION

CONDUIT & CONDUCTOR SIZE PER NEC REQ'MTS 3" DIA MINIMUM

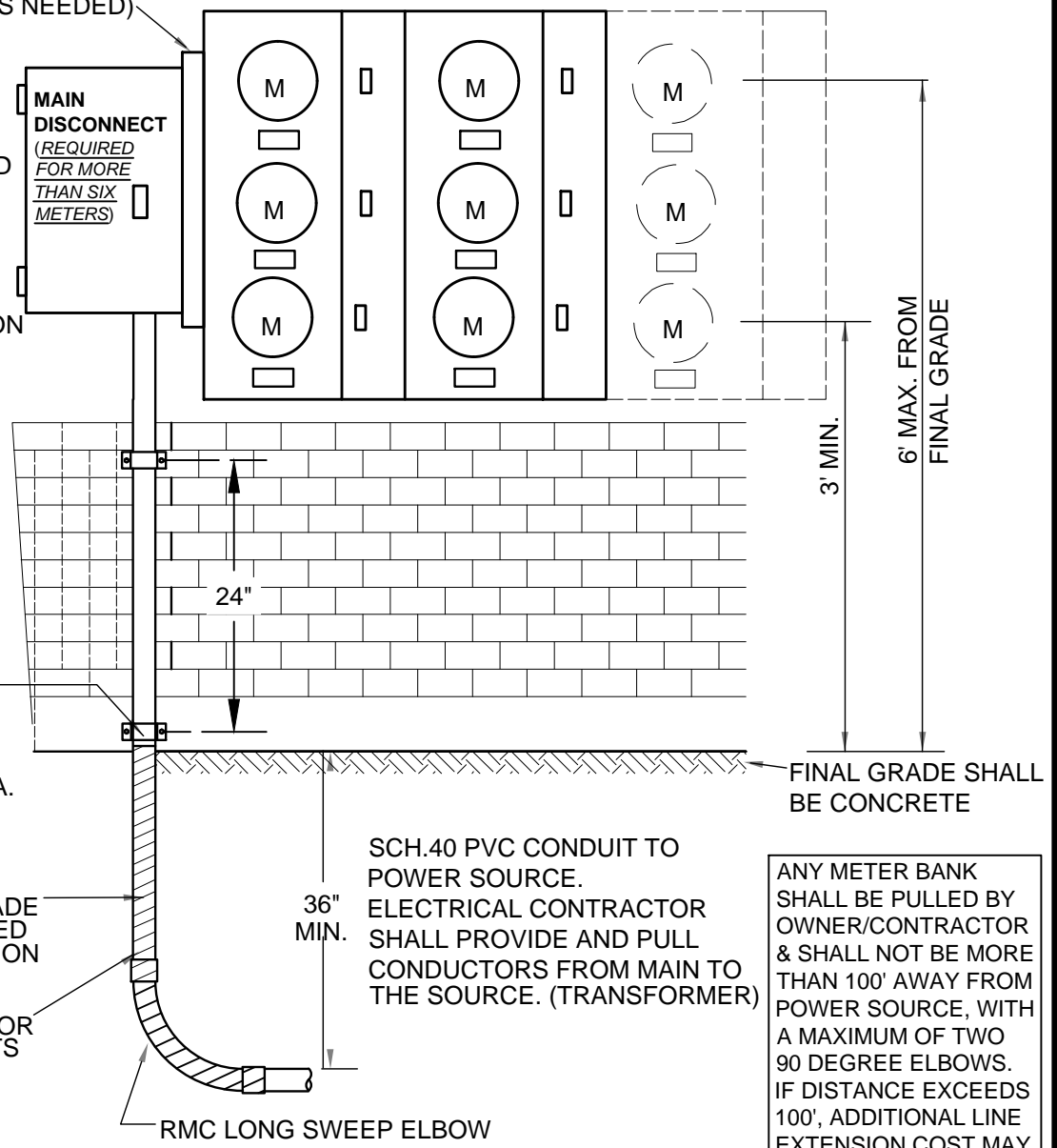

NOTES:

1. OWNER/BUILDER SHALL PROVIDE AND INSTALL CONDUIT AND PROVIDE AND PULL CONDUCTOR FROM THE TRANSFORMER TO THE LINE SIDE OF THE BANKED METER BASE.
2. OWNER SHALL MAINTAIN CONDUIT AND CONDUCTOR FROM TRANSFORMER TO METER.
3. CONDUIT CLAMP(S) MUST BE ABOVE GROUND.
4. INSPECTION REQUIRED PRIOR TO BACKFILL OF TRENCH. REFER TO 4.2.1
5. INSPECTION BY LOCAL MUNICIPAL BUILDING INSPECTOR REQUIRED PRIOR TO PERMANENT POWER CONNECTION
6. A MAIN DISCONNECT IS REQUIRED WHEN MORE THAN SIX (6) SERVICES/METERS ARE CONNECTED. IF AN EXISTING INSTALLATION EXPANDS BEYOND SIX (6) SERVICES, A MAIN DISCONNECT SHALL BE INSTALLED.

ANY METER BANK SHALL BE PULLED BY OWNER/CONTRACTOR & SHALL NOT BE MORE THAN 100' AWAY FROM POWER SOURCE, WITH A MAXIMUM OF TWO 90 DEGREE ELBOWS. IF DISTANCE EXCEEDS 100', ADDITIONAL LINE EXTENSION COST MAY BE REQUIRED.



**REQUIREMENTS & STANDARDS**  
**MULTI-METER INSTALLATION**  
**UNDERGROUND SERVICE**

200 AMP & GREATER, SELF CONTAINED METERING

DWG: **6.1.3**

REV. 0.00

BY: JB/MA

DATE: 1/20/25



**CT-METERING REQUIRED:**

CURRENT TRANSFORMER (C.T.) METERING IS REQUIRED WHEN A SINGLE-PHASE OR THREE-PHASE SERVICE EXCEEDS 400 AMPERES. FOR SERVICES OVER 800 AMPERES SEE SECTION ON SWITCHBOARD METERING.

MAIN SERVICE DISCONNECT IS REQUIRED TO BE OUTSIDE AT METER LOCATION. THE C.T. METERING EQUIPMENT SHALL BE MOUNTED IN A LOCATION APPROVED BY HEBER LIGHT & POWER. CURRENT TRANSFORMERS **SHALL NOT BE INSTALLED** INSIDE OF THE PAD MOUNT TRANSFORMER.

WHEN METERING EQUIPMENT IS INSTALLED AT A LOCATION WHERE IT MAY BE STRUCK BY A VEHICLE, THE CUSTOMER IS REQUIRED TO INSTALL AND MAINTAIN AN APPROVED BARRIER POST. BARRIER POST (6" DIAMETER, CONCRETE FILLED) WHERE METERING EQUIPMENT IS INSTALLED IN VEHICLE TRAFFIC AREA.

**THE CUSTOMER SHALL PROVIDE AND INSTALL:**

THE WEATHER TIGHT METALIC CABINET (NEMA 3R, EUSERC 316 OR EQUAL, 24" x 48" x 11" FOR SINGLE PHASE AND 36"x48"x11" FOR THREE PHASE MINIMUM) SEALABLE WITH A LOCKABLE HINGED DOOR, SECURELY MOUNTED ON A RIGID SURFACE. THE TOP OF THE CABINET SHALL BE NO MORE THAN 6 FEET FROM FINAL GRADE.

EUSERC APPROVED (EUSERC 328A FOR SINGLE PHASE, 329A FOR THREE PHASE) CURRENT TRANSFORMER MOUNTING BASE RATED 50,000 AMPERE FAULT DUTY.

THE CURRENT TRANSFORMER METER SOCKET WITH A SPACE RESERVED BELOW THE SOCKET FOR A TEST SWITCH (EUSERC 339) SHALL BE MOUNTED SO THAT THE CENTER OF THE METER IS 5'4" MINIMUM FROM THE FINAL GRADE. METER SOCKETS WITH CIRCUIT CLOSURES OR BYPASS CLIPS **ARE NOT APPROVED**.

THE CONDUIT BETWEEN THE METER SOCKET AND THE C.T. CABINET. RIGID 1" MINIMUM WITH PROPER FITTINGS AND BUSHINGS, NOT TO EXCEED 12" IN LENGTH.

TERMINATE WITH APPROVED CONNECTORS THE CONDUCTORS BETWEEN THE TRANSFORMER AND THE LINE SIDE OF THE CURRENT TRANSFORMER-MOUNTING BASE.

TERMINATE WITH APPROVED CONNECTORS THE CONDUCTORS BETWEEN THE CUSTOMER PANEL AND THE LOAD SIDE OF THE CURRENT TRANSFORMER-MOUNTING BASE.

GROUNDING PER NEC (ARTICLE 250 GROUNDING) FOR ALL METER AND CURRENT TRANSFORMER ENCLOSURES. (SEE 7.4.1, 7.4.2)

**HEBER LIGHT & POWER SHALL OWN, PROVIDE AND INSTALL:**

THE METER AND TEST SWITCH.

THE CURRENT TRANSFORMERS.

THE WIRING BETWEEN THE CURRENT TRANSFORMER AND THE METER SOCKET ENCLOSURE.

**ANY CHANGES OR DEVIATIONS MUST HAVE PRIOR WRITTEN APPROVAL FROM HEBER LIGHT & POWER.**



**REQUIREMENTS & STANDARDS  
ELECTRICAL SERVICE  
REQUIREMENTS  
CT METERING 800 AMP MAX.  
COMMERCIAL/1 PHASE-3 PHASE POWER SERVICE**

DWG: **6.2.1**

REV. 0.00

BY: JB/MA

DATE:11/14/24

**SWITCH BOARD METERING**

A EUSERC (EUSERC 354 OUTDOOR) SWITCHBOARD METERING SECTION IS REQUIRED WHEN THE SERVICE ENTRANCE RATING IS GREATER THAN 800 AMPERES. THE METERING CURRENT TRANSFORMERS WILL BE LOCATED IN THE CURRENT TRANSFORMER COMPARTMENT. THE METER AND TEST SWITCH MAY BE MOUNTED ON THE HINGED COVER OF THE COMPARTMENT OR MOUNTED REMOTELY WITH HEBER LIGHT & POWER APPROVAL. THE AREA BELOW THIS COMPARTMENT'S BARRIER MAY BE USED AS A MAIN SWITCH (BREAKER) COMPARTMENT, OR A LOAD DISTRIBUTION COMPARTMENT. THE METERING COMPARTMENT SHALL BE ON THE SUPPLY SIDE OF THE MAIN SWITCH OR BREAKER.

THE MOUNTING PAD FOR ALL SWITCHBOARD METERING ENCLOSURES WILL BE A MINIMUM 4" THICK CONCRETE PAD, EXTENDING 3' IN FRONT OF THE ENCLOSURE TO ENSURE AN ADEQUATE AND SAFE WORK AREA.

**THE CUSTOMER WILL PROVIDE AND INSTALL:**

THE CONDUIT AND CONDUCTORS, A MAXIMUM OF 32 CONDUCTORS NOT TO EXCEED 750 MCM MAXIMUM, CONDUCTOR SIZED PER NEC ACCORDING TO THE FULL LOAD CAPACITY OF THE TRANSFORMER.

THE SWITCHBOARD SERVICE SECTION, CURRENT TRANSFORMER MOUNTING BASE, PANELS, PULLING SECTION SEPERATE FROM THE CT COMPARTMENT, METER SOCKET AND PROVISIONS FOR A TEST SWITCH.

CURRENT TRANSFORMER BUSS BARS, AND TERMINATING BOLTS MUST BE SECURED IN PLACE AND SHALL BE PROVIDED WITH NUTS, FLAT WASHER, SPRING WASHERS, AND ALL PARTS MUST BE PLATED TO PREVENT CORROSION. BUSS BARS ARE REQUIRED FROM THE PULL SECTION INTO THE SERVICE SECTION.

ALL PULL AND TERMINATION SECTIONS SHALL BE FULL FRONT ACCESS. COVER PANELS SHALL BE REMOVABLE, SEALABLE, AND PROVIDED WITH TWO LIFTING HANDLES, AND LIMITED TO 9 SQUARE FEET IN AREA.

ALL REMOVABLE PANELS AND COVERS TO THE COMPARTMENTS USED FOR TERMINATING OR ROUTING CONDUCTORS SHALL HAVE SEALING PROVISIONS.

GROUNDING MUST MEET NEC REQUIREMENTS. LUGS FOR TERMINATING THE CUSTOMER'S GROUND WIRE SHALL BE LOCATED OUTSIDE OF THE SEALABLE SECTION AND SHALL BE DESIGNED TO READILY PERMIT THE CUSTOMER'S NEUTRAL SYSTEM TO BE ISOLATED, WHEN NECESSARY, FROM HEBER LIGHT & POWER'S NEUTRAL.

THE NEC REQUIRES A CLEAR WORKSPACE OF 78" HIGH BY 70" WIDE BY 48" DEEP IN FRONT OF METERING EQUIPMENT.

**HEBER LIGHT & POWER WILL OWN, PROVIDE AND INSTALL:**

THE METER AND TEST SWITCH.  
THE CURRENT TRANSFORMERS.  
THE WIRING BETWEEN THE CURRENT TRANSFORMERS AND THE METER TEST SWITCH.

**ANY CHANGES OR DEVIATIONS MUST HAVE PRIOR WRITTEN APPROVAL BY HEBER LIGHT & POWER METERING DEPARTMENT.**



**REQUIREMENTS & STANDARDS**  
**REQUIREMENTS FOR**  
**ELECTRIC SERVICE**  
**SWITCHBOARD METERING**  
**OVER 400 AMP COMMERCIAL & INDUSTRIAL 3^ POWER**

DWG: **6.3.1**

REV. 0.00

BY: JB/MA

DATE:11/14/24

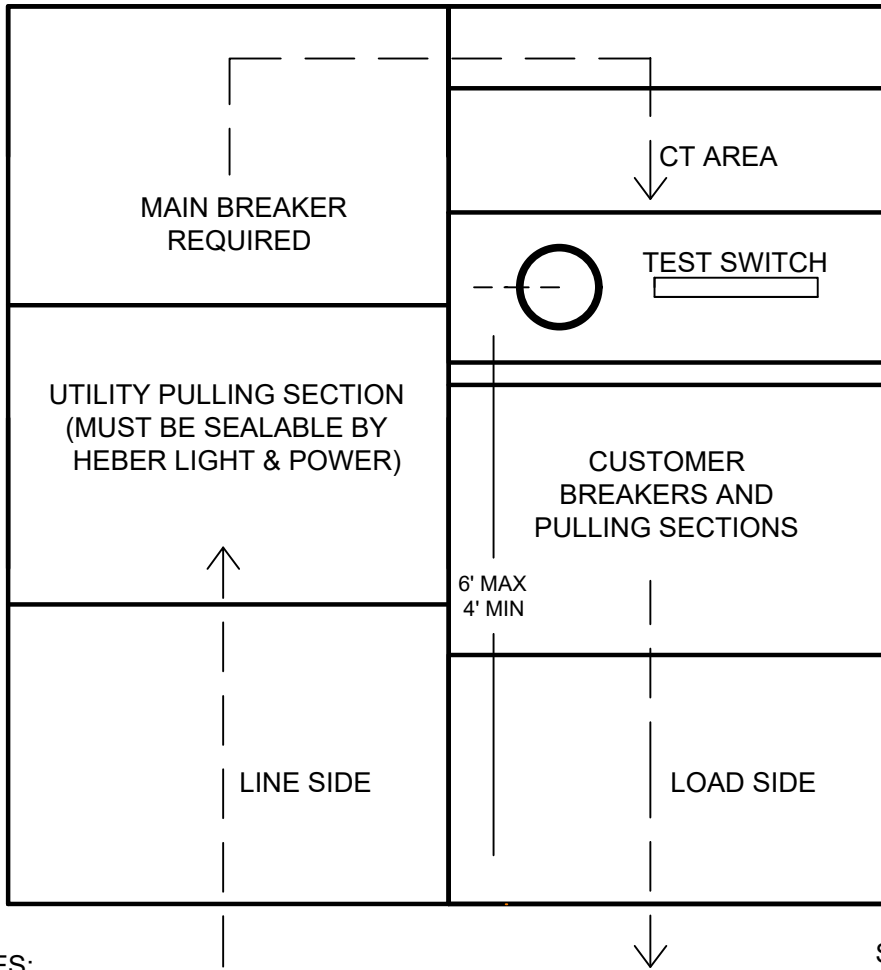

SERVICE SECTION WITH  
CT METERING FOR  
SERVICES  
OVER 800 AMP  
(MUST BE SEALABLE BY  
HEBER LIGHT & POWER)

NOTES:

STANDING SURFACE

1. MINIMUM PULLING SECTION DIMENSIONS: 800-1200 AMP 30" WIDE; 1200-2000 AMP 35" WIDE.
2. FOR SWITCHBOARD RATINGS ABOVE 2000 AMP CONSULT HEBER LIGHT & POWER.
3. BUS BARS, WITH PROVISIONS FOR TERMINATION LUGS AS EUSERC 347 ARE REQUIRED FROM THE PULL SECTION INTO THE SERVICE SECTION.
4. CUSTOMER SHALL PROVIDE A DRAWING WITH DIMENSIONS OF PROPOSED SERVICE EQUIPMENT.
5. EXTERIOR DOORS ON SWITCHBOARDS MUST BE SEALABLE AND HOLD SECURELY AT 90°.
6. METER PANELS SHALL NOT BE HINGED ON A FILLER PANEL. HINGED METER PANEL MUST BE CAPABLE OF BEING OPENED 90° WITH METER IN PLACE.
7. A BARRIER IS REQUIRED INSIDE THE SERVICE SECTION BETWEEN THE CT COMPARTMENT AND THE CUSTOMER PULLING SECTION.
8. CONDUIT AND CONDUCTOR TO BE SUPPLIED, INSTALLED, TERMINATED & MAINTAINED BY OWNER/CONTRACTOR PER NEC, FROM THE SWITCHBOARD TO THE POWER SOURCE SUPPLIED BY HEBER LIGHT & POWER.
9. SERVICE DISCONNECTS RATED 1000 OR MORE AND WITH A VOLTAGE LINE TO GROUND GREATER THAN 150V SHALL BE PROVIDED WITH GROUND FAULT PROTECTION OF EQUIPMENT (GFPE)



**REQUIREMENTS & STANDARDS**  
**SWITCHBOARD SERVICE**  
**800 AMP & GREATER**

COMMERCIAL AND INDUSTRIAL SERVICES

DWG: **6.3.2**

REV. 0.00

BY: JB/MA

DATE:11/14/24

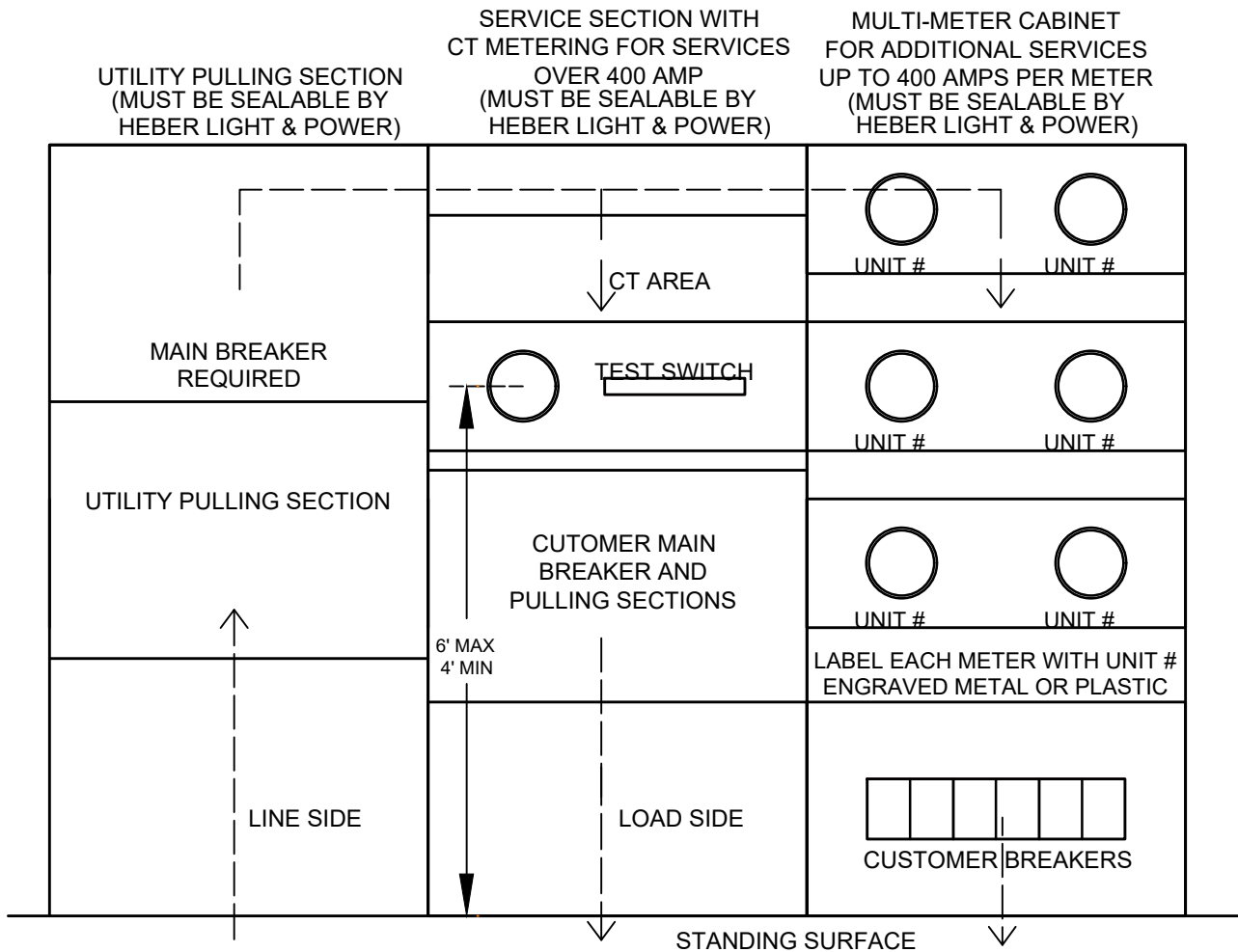

**NOTES:**

1. MINIMUM PULLING SECTION DIMENSIONS: 800-1200 AMP 30" WIDE; 1200-2000 AMP 35" WIDE.
2. FOR MULTI METER CABINET RATINGS ABOVE 2000 AMP CONSULT HEBER LIGHT & POWER ENGR.
3. BUS BARS, WITH PROVISIONS FOR TERMINATION LUGS AS EUSERC 347 ARE REQUIRED FROM THE PULL SECTION INTO THE SERVICE SECTION.
4. CUSTOMER SHALL PROVIDE A DRAWING WITH DIMENSIONS OF PROPOSED SERVICE EQUIPMENT.
5. EXTERIOR DOORS ON SWITCHBOARDS MUST BE SEALABLE AND HOLD SECURELY AT 90°.
6. METER PANELS SHALL NOT BE HINGED ON A FILLER PANEL. HINGED METER PANEL MUST BE CAPABLE OF BEING OPENED 90° WITH METER IN PLACE.
7. A BARRIER IS REQUIRED INSIDE THE SERVICE SECTION BETWEEN THE CT COMPARTMENT AND THE CUSTOMER PULLING SECTION.
8. MAIN SERVICE DISCONNECT IS REQUIRED OUTSIDE AT THE METER LOCATION. METER LOCATION SHALL BE APPROVED BY HEBER LIGHT & POWER.
9. SERVICE DISCONNECTS RATED 1000 AMP OR MORE AND WITH A VOLTAGE LINE TO GROUND GREATER THAN 150V SHALL BE PROVIDED WITH GROUND FAULT PROTECTION OF EQUIPMENT (GFPE).
10. CONDUIT & CONDUCTOR TO BE SUPPLIED, INSTALLED, TERMINATED & MAINTAINED BY OWNER / CONTRACTOR PER NEC, FROM THE SWITCHBOARD TO THE POWER SOURCE SUPPLIED BY HEBER LIGHT & POWER.
11. NO COMPARTMENTS OR SECTIONS TO SHARE UNMETERED AND METERED CONDUCTORS.



**REQUIREMENTS & STANDARDS  
SWITCHBOARD SERVICE  
800 AMP & GREATER**

COMMERCIAL AND INDUSTRIAL SERVICES

DWG: <b>6.3.3</b>
REV. 0.00
BY: JB/MA
DATE: 11/14/24